

Models

P40U, P40U-F,
P40U-P, P40U-W
LOW INTENSITY TUBE TYPE
INFRA RED HEATERS

&

Models

P40U-I, P40U-I-F,
P40U-IP, P40U-IW
LOW INTENSITY TUBE TYPE
INFRA RED HEATERS

INSTALLATION / OWNER'S MANUAL



WARNING Improper installation, adjustment, alteration, service or maintenance can cause property damage, injury or death.
Read the installation and operating and maintenance instructions thoroughly before installing or servicing this equipment.

SAFETY ALERT:



This heater must be installed and serviced only by a trained gas service technician. Failure to comply could result in personal injury, death, fire and/or property damage.

Do not store or use gasoline or other flammable vapours and liquids in the vicinity of this or any other gas fired appliance.



IF YOU SMELL GAS:

- Extinguish any open flame
- Do not attempt to light this or any other appliance
- Don't touch any electrical switch, or telephone
- Immediately call your gas supplier from a neighbor's phone
- Follow any and all instruction from your gas supplier
- If your gas supplier is not available, call the fire department



FIELD CONVERTIBILITY:
This appliance is field convertible to LP gas using an optional kit supplied by the manufacturer

Keep this manual in a secure place .
Record for future reference:

Model #: _____

Serial #: _____

(located on heater rating label)



NOTICE:

This manual is current for this product. Occasional revision of the product Certification Standard may require changes to the product and/or this manual.

This publication, or parts thereof, may not be reproduced in any form, without prior written consent from The Manufacturer. Unauthorized use or distribution of this publication is strictly prohibited.

Schwank Group

*5285 Bradco Boulevard
Mississauga, Ontario, L4W 2A6
PO Box 988, 2 Schwank Way
Waynesboro, Georgia 30830*

Customer & Technical Services

*Phone: 877-446-3727
Fax: 866-361-0523
e-mail: csr@schwankgroup.com*

www.schwankgroup.com

www.infrasave.com

P40U (-P, -W) / P40U-I (-IP,-IW) SERIES GAS FIRED INFRARED LOW INTENSITY U-TUBE TYPE

TABLE OF CONTENTS



IMPORTANT INFORMATION - READ FIRST

APPLICATION	4
HEATER EXPANSION	5, 31
GAS CONNECTION	5, 31
VENTING	5, 26
START UP 'SMOKE'	5
THERMOSTAT COMFORT SETTING	5
CLEARANCE TO COMBUSTIBLES	6
Clearances Figure & Table	7
STACKING HEIGHT SIGN	8

TOPICPAGE

1. LABOR REQUIREMENTS	9
2. INSTALLATION IN AIRCRAFT HANGARS	9
3. INSTALLATION IN COMMERCIAL GARAGES	9
4. INSTALLATIONS OTHER THAN SPACE HEATING.....	9
5. PRE-INSTALLATION SURVEY.....	10
6. MOUNTING CLEARANCES.....	10
SERVICE CLEARANCE	11
7. HEATER PLACEMENT GUIDELINES	11
8. HEATER INSTALLATION	12
TURBULATORS	15
8A SEISMIC RESTRAINT.....	16
8B HIGH WIND RESTRAINT.....	16
9. FLUE VENTING.....	17
10. COMBUSTION AIR DUCTING.....	20
11. GAS SUPPLY & CONNECTION	21
ORIENTATION OF FLEXIBLE GAS CONNECTION.....	22
12. GAS CONVERSION.....	23
13. ELECTRICAL AND THERMOSTAT	24
14. HIGH ALTITUDE INSTALLATION.....	24
15. LIGHTING INSTRUCTIONS	24
16. RECOMMENDED MAINTENANCE	24
17. WIRING DIAGRAM: FENWAL DSI: MODELS P40U, P40U-I	25
18. WIRING DIAGRAM MULTIPLE HEATERS PER THERMOSTAT	26
19. FENWAL DSI OPERAT6ION	27

TOPICPAGE

20. WIRING DIAGRAM: P40U-P, P40U-W	30
21. SEQUENCE OF OPERATION P40U-P, P40U-W.....	31
22. GASLITER MICRO 50N DSI	32
23. SPARK IGNITER SET UP	34
24. TROUBLESHOOTING GUIDE	35
25. START- UP / COMMISSIONING SHEET	36

PRODUCT DIMENSIONS & DATA

26. HEATER DIMENSIONS / WEIGHTS	39
27. HIGH ALTITUDE & ORIFICE CHART.....	40
28. OPTIONAL ACCESSORIES.....	41
29. REPLACEMENT PARTS LIST	45

HONEYWELL S87J DSI

WIRING DIAGRAM - S87J	48
SEQUENCE OF OPERATION - S87J	49
FLAME SENSING CIRCUIT - S87J	50
WARRANTY STATEMENT	BACK PAGE

FIGURES:

FIG 1 - CLEARANCE TO COMBUSTIBLES	7
FIG 2 - SERVICE CLEARANCE.....	11
FIG 3 - TYPICAL MOUNTING HARDWARE.....	13
FIG 4 - TYPICAL SUSPENSION	14
FIG 5 - HEATER DIMENSIONS & SUSPENSION ANGLE OPTIONS.....	14
FIG 6 - CLEARANCE TO COMBUSTIBLES (repeated).....	15
FIG 7 - SEISMIC RESTRAINT	16
FIG 8 - HIGH WING RESTRAINT	16
FIG 9 - HEATER EXPANSION - VENT	18
FIG 10 - HORIZONTAL VENT	18
FIG 11 - ROOF VENT	20
FIG 12 - ORIENTATION OF FLEXIBLE GAS	22
FIG 13 - INCORRECT FLEXIBLE GAS.....	23
DIMENSIONS & WEIGHTS.....	39
WIRING DIAGRAMS: FENWAL DSI	25,
MULTIPLE HEATERS PER THERMOSTAT ...	26
CHANNEL GASLITER MICRO 50N DSI.....	30
HONEYWELL S87J DSI	48



WARN-



Improper installation, adjustment, alteration, service or maintenance can cause property damage, injury or death. Read and understand this installation and operation manual thoroughly prior to assembly, installation, operation or service to this appliance.



This heater must be installed and serviced only by a trained gas service technician.

Do not store or use gasoline or other flammable vapours and liquids in the vicinity of this or any other gas fired appliance.



Failure to comply could result in personal injury, death, fire and/or property damage.

Do not store or use gasoline or other flammable vapours and liquids in the vicinity of this or any other gas fired appliance.

This appliance may have sharp edges and corners. Wear protective clothing such as gloves and protective eye wear when servicing this or any other appliance.

INSPECT PRODUCT UPON RECEIPT

Inspect the carton and heater for concealed damage. Note any damage on the Bill of Lading and make any damage claim to the transport company as soon as possible.

APPLICATION

It is beyond the scope of these instructions to consider all conditions that may be encountered. Installation must conform with local building codes or, in the absence of local codes, with the National Fuel Gas Code, ANSI Z223.1/NFPA 54 in the U.S.A. or the Natural Gas and Propane Installation Code, CSA B149.1 in Canada. The latest edition Electrical Code ANSI/NFPA N0 70 in the U.S.A. and PART 1 CSA C22.1 in Canada must also be observed.

Installation of a gas fired tube heater must conform to all heating installation procedures including clearance to combustibles, connection to the gas and electrical supplies, and ventilation.

This heater is not for installation in a Class 1 or Class 2 explosive environment. If the application is in question, consult with local authorities having jurisdiction (Fire Marshall, labor department, insurance underwriter, or other authority).

Revisions to codes and/or standards, may require revision to equipment and installation procedures. In case of discrepancy, the latest codes, standards, and installation manual will take priority over prior releases.

MODELS AVAILABLE in the Schwank P40U & InfraSave P40U-I Series:

Models P40U and P40U-I may be installed for heating of commercial/industrial **indoor spaces**.

Models P40U-P and P40U-IP have a powder coated water resistant burner enclosure and may be installed for heating of commercial / industrial **outdoor spaces and wet indoor environments**.

Models P40U-W and P40U-IW have a stainless steel water resistant burner enclosure and may be installed for heating of commercial / industrial **outdoor spaces and harsh wet indoor environments**.



WARNING

Heater Expansion



It is a normal condition that during heat-up and cool-down a tube heater will expand and contract. Allowances for heater expansion must be made in the gas connection, venting and combustion air ducting. Improper installation, alteration, or adjustment can result in property damage, injury or death. **Refer to Section 11**



WARNING

Gas Connection



Improper installation, connection, or adjustment can result in property damage, toxic gases, asphyxiation, injury or death. Using an approved flexible gas connector in the USA or Type 1 hose connector in Canada, the gas supply to the heater must be connected and tested in accordance with all local, state, provincial, and national codes (ANSI Z223.1/NFPA 54 in USA; B149.1 in Canada) and as indicated in this manual. **Refer to Section 11**



WARNING

Venting



Inadequate venting of a heater may result in asphyxiation, carbon monoxide poisoning, injury or death. This heater may be directly or indirectly vented from the space. Venting must be in accordance with all local, state, provincial, and national codes (ANSI Z223.1/NFPA 54 in USA; B149.1 in Canada) and as indicated in this manual. **Refer to Sections 9 & 10**



WARNING

Start-Up 'SMOKE' Condition

During start up, the heating of material coatings used in the production process of tubes and reflectors will create smoke during the initial period of operation. This condition is normal and temporary .

Ensure that there is sufficient ventilation to adequately clear any smoke from the space.

Notify site and safety personnel to ensure that alarm systems are not unduly activated.



IMPORTANT

THERMOSTAT SETTING FOR COMFORT

Infrared radiant (IR) heating system provide comfort with the effect of radiant heat and ambient air heat.

If your IR system is controlled with a thermostat (TruTemp or ThermoControl Plus) that senses radiant heat, then set the thermostat to the desired comfort temperature (ie: 65°; 68°; 20°C).

If your IR system is controlled with a standard 24V or 120V thermostat that senses only air temperature, then start with a thermostat setting that is 5° to 7°F (3° to 5°C) lower than the desired comfort temperature. Some trial and error setting may be required to 'fine tune' the comfort temperature that best suits your site and provides most economical operation.



WARN-

Clearance to combustibles

Location of flammable or explosive objects, liquids or vapors close to the heater may cause fire or explosion and result in property damage, injury or death. Do not use, store or locate flammable or explosive objects, liquids or vapors in proximity of the heater.



The clearance to combustible material represents the minimum distance that must be maintained between the outer heater surface and a nearby surface. The stated clearance to combustibles represents a surface temperature of 90F° (50C°) above room temperature. It is the installer's responsibility to ensure that building materials with a low heat tolerance which may degrade at lower temperatures are protected to prevent degradation. Examples of low heat tolerance materials include vinyl siding, fabrics, some plastics, filmy materials, etc.

In locations used for the storage of combustible materials, signs must be posted to specify the maximum permissible stacking height to maintain the required clearances from the heater to the combustibles. Such signs must either be posted adjacent to the heater thermostats or in the absence of such thermostats in a conspicuous location. In addition to stored or stationary material, consideration must also be given to moveable objects such as cranes, vehicles, and overhead doors, and structural objects such as sprinkler heads, electrical and gas lines, and electrical fixtures.

It is beyond the scope of these instructions to consider all conditions that may be encountered. Consult local authorities such as the Fire Marshall, insurance carrier, or safety authorities if you are uncertain as to the safety or applicability of the proposed installation.

Refer to Figure 1 and Table 1 for the certified clearances to combustibles for the appropriate model input/size.

NOTE: A 'PEEL & STICK' SIGN IS SUPPLIED: USE AN INDELIBLE MARKER TO ENTER VALUES ON THE SIGN: 'H' = Calculate (instruction below)
 Sides of horizontal heater: 'S' = 24 inches (61 cm)
 Front of 30° Angle heater: 'F' = 36 inches (91.5 cm)
 Behind 30° Angle Heater 'B' = 24 inches (61 cm)

POST THE SIGN ADJACENT TO THE HEATER THERMOSTAT OR IN A PROMINENT LOCATION. See next page for details.



FIGURE 1 MINIMUM CLEARANCES TO COMBUSTIBLES* - Table 1 lists values

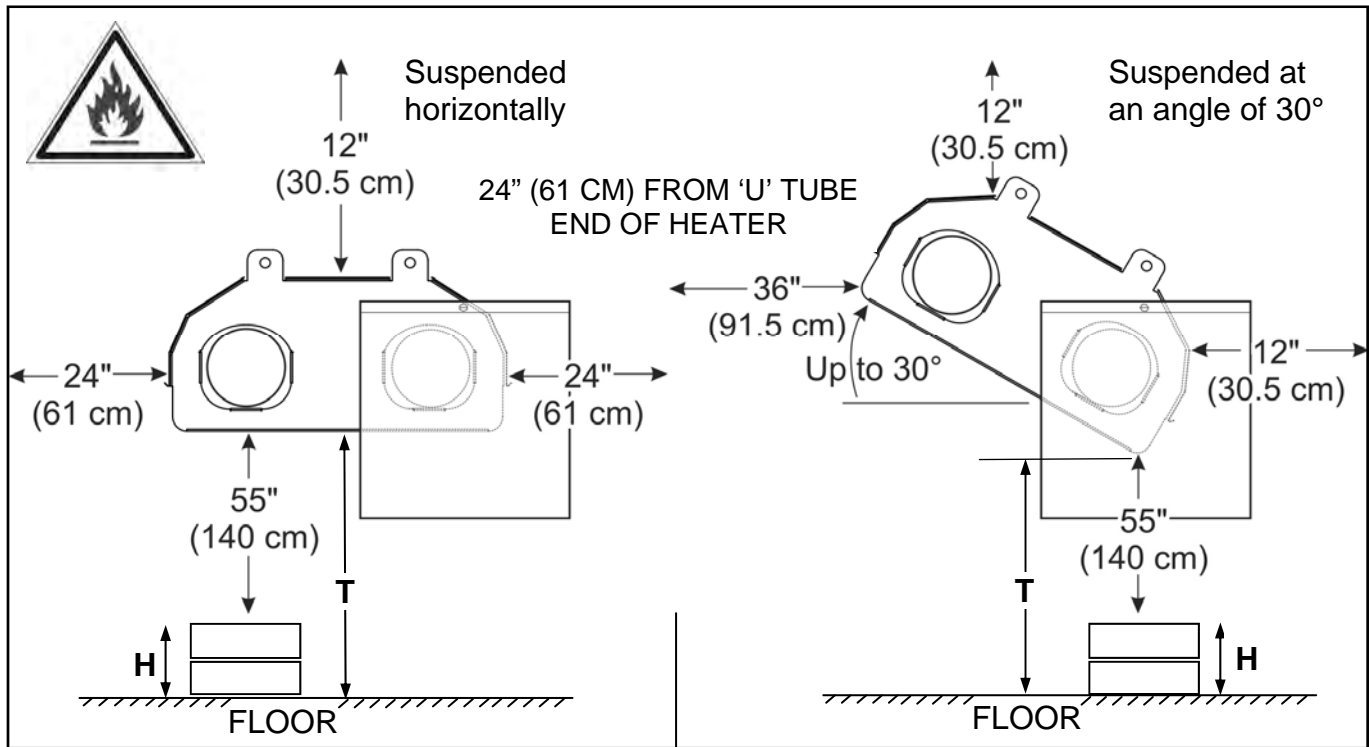

Calculate Maximum Stack Height 'H': (Enter value 'H' on the peel and stick label supplied)

- $H = T - 55$ inches (140 cm)
- 'T' is measured on site = distance from the bottom of the heater hanger to the floor
- 55 inches (140 cm) is the required minimum clearance below the heater

TABLE 1 MINIMUM CLEARANCES TO COMBUSTIBLE SURFACES OR MATERIALS*

MODELS	SUSPENDED HORIZONTALLY			SUSPENDED AT AN ANGLE UP TO 30 DEGREES			
	TOP inches (cm)	BELOW inches (cm)	SIDES inches (cm)	TOP inches (cm)	BELOW inches (cm)	FRONT inches (cm)	BEHIND inches (cm)
P40U / P40U-I P40U-P / P40U-IP P40U-W/P40U-IW	12 (30.5)	55 (140)	24 (61)	12 (30.5)	55 (140)	36 (91.5)	12 (30.5)
Clearance from 'U' end of heater (horizontal or angled): 24" (61 cm)							

*The clearance to combustible materials represents the minimum distance that must be maintained between the heater and a nearby surface. The stated clearance to combustibles represents a surface temperature of 90F° (50C°) above room temperature.

It is the installer's responsibility to ensure that building materials with a low heat tolerance which may degrade at lower temperatures are protected to prevent degradation. Examples of low heat tolerance materials include vinyl siding, fabrics, some plastics, filmy materials, some coatings and laminated finishes, etc.

VENT END CLEARANCE: Clearances from the vent pipe are determined by local or national installation codes, but must not be less than 6 inches (15 cm). For 'unvented' installation, a minimum distance of 24 inches (61 cm) is required from the end of heater to a combustible surface.

WARNING In locations used for the storage of combustible materials: **Signs must be posted** specifying the *maximum permissible stacking height* to maintain the required clearances from the heater to the combustibles.

The signs must be posted either adjacent to the IR heating system thermostats or in the absence of such thermostats, in a conspicuous place.

For your convenience a "peel and stick" sign is provided with this heater. Use a permanent marker to record the required dimensions on the sign.

'H' is a value calculated at site: $(H = T - C)$

- Measure the on site distance between bottom of the hanger and the floor = 'T' inches (cm).
- The minimum clearance to combustibles below this model heater is 55 inches (140 cm)
- Subtract 55 inches (140 cm) from 'T' to get value 'H'.
- Enter the calculated value 'H' on the sign

For model P40U enter the values for other dimensions are: 'S' = 24" (61 cm), 'F' = 36" (91.5 cm) and 'B' = 12" (30.5 cm). See Figure 1 and Table 1

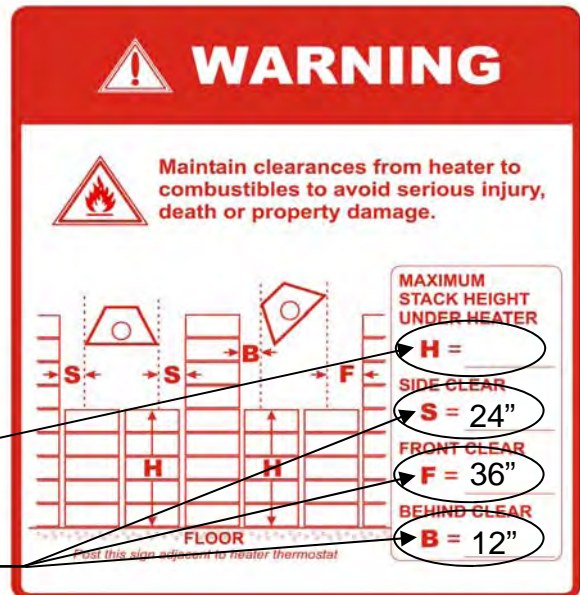

Post this sign as instructed above.

1. LABOR REQUIREMENTS

Two persons are required to safely install this equipment. SHARP EDGES - Wear gloves and other required safety protection.

2. INSTALLATION IN COMMERCIAL AIRCRAFT HANGARS

Low intensity radiant tube heaters are suitable for use in aircraft hangars when installed in accordance with the latest edition of the Standard for *Aircraft Hangars*, ANSI/NFPA No 409 in the USA, or the Canadian *Natural Gas and Propane Installation Code*, B149.1.

- A. A minimum clearance of 8 ft (2.4 m) must be maintained from the bottom of the heater to the floor in other sections of the aircraft hangar, such as offices and shops, which communicate with areas for servicing or storage. Refer to Table 1 for proper mounting clearances to combustibles.
- B. Heaters must be located so as to be protected from damage by aircraft and other objects, such as cranes and movable scaffolding.
- C. Heaters must be located so as to be accessible for servicing and adjustment.

3. INSTALLATION IN COMMERCIAL GARAGES AND PARKING STRUCTURES

Low Intensity Heaters are suitable for use in commercial garages when installed in accordance with the latest edition of the Standard for *Parking Structures*, ANSI/NFPA 88A, or the Standard for *Repair Garages*, ANSI/NFPA No. 88B, or the Canadian *Natural Gas and Propane Installation Code*, B149.1.



WARNING

An overhead heater shall be located high enough to maintain the minimum distance to combustibles, as shown on the heater rating plate, from the heater to any vehicles parked below the heater.

Overhead heaters shall be installed at least 8 ft (2.4 m) above the floor.

4. INSTALLATIONS OTHER THAN SPACE HEATING

Use for process or other applications that are not space heating will void the C.S.A. certification and product warranty. Process application requires field inspection and/or certification by local authorities having jurisdiction.



WARNING



Improper installation, adjustment, alteration, service or maintenance can cause property damage, injury or death. Read and understand this installation and operation manual thoroughly prior to assembly, installation, operation or service to this appliance.



This heater must be installed and serviced only by a trained gas service technician.

Do not store or use gasoline or other flammable vapours and liquids in the vicinity of this or any other gas fired appliance.



Failure to comply could result in personal injury, death, fire and/or property damage.

Do not store or use gasoline or other flammable vapours and liquids in the vicinity of this or any other gas fired appliance.

5. PRE INSTALLATION SURVEY

It is recommended that a full heating design including heat loss calculation be conducted on the structure or area to be heated. Heater sizing and placement must consider available mounting height, sources of greatest heat loss, and the certified clearances to combustibles with respect to stored material, moveable objects (cranes, vehicles, lifts, overhead doors, etc), sprinkler system heads, and other obstructions on the site. Consideration must also be given to vent / duct placement and the allowable combined lengths of vent and duct. Carefully survey the area to be heated, and for best results place burner and combustion chamber in the coldest area(s) .

Installation must conform with all local, state, provincial and national code requirements including the current latest edition ANSI Z223.1 (NFPA 54) in the U.S.A. and B149.1 installation code in Canada, for gas burning appliances and equipment. The latest edition Electrical Code ANSI/NFPA N0 70 in the U.S.A. and PART 1 CSA C22.1 in Canada must also be observed.

The heating system must have gas piping of the correct diameter, length, and arrangement to function properly. For this reason, a layout drawing is necessary.

6. MOUNTING CLEARANCES

This heater must be mounted with at least the minimum clearances between the heater and combustibles as shown in FIG-1, TABLE 1, Page 7. **It is the installer's responsibility to ensure that building materials with a low heat tolerance which may degrade at lower temperatures are protected to prevent degradation. Examples of low heat tolerance materials include vinyl siding, fabrics, some plastics, filmy materials, some coatings and laminated finishes, etc.**

Ensure adequate clearance around the air intake at the burner to allow sufficient combustion air supply to the heater.

Proximity of lights, sprinkler heads, overhead doors, storage areas, gas and electrical lines, parked vehicles, cranes and any other possible obstruction or hazard must be evaluated.

It is recommended that Protective Guard JS-0502-UR-GK be installed on any heater mounted with less than 8 feet from floor to bottom of heater (See Accessories - Page 42).

6A. SERVICE CLEARANCE: The lower ‘jaw’ of the burner cabinet swings down to provide convenient service access to burner components. Provide a minimum clearance from any wall or obstruction of 6 inches (15 cm) to the access end of the burner housing, and a minimum of 24 inches (61 cm) to any ONE side to allow burner service. (see Figure 2 below)

The minimum clearances to combustibles must always be maintained.

FIGURE 2

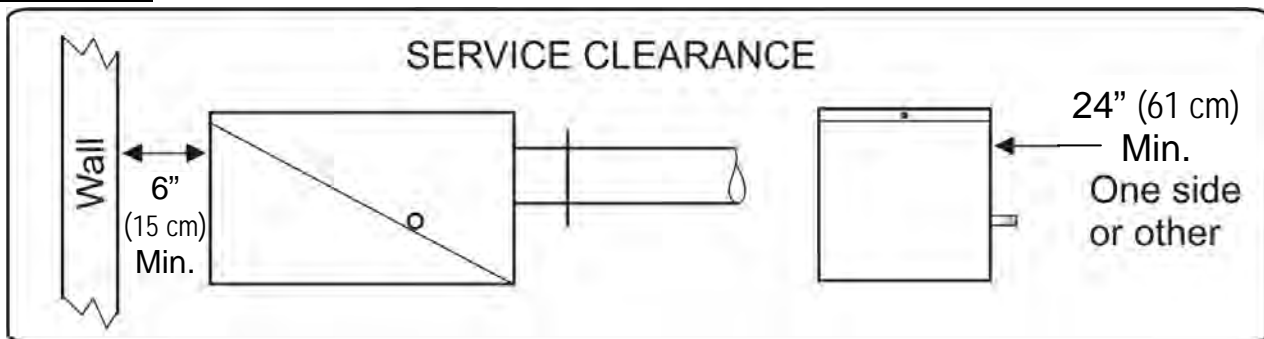

7. GUIDELINES FOR HEATER PLACEMENT* - SPACE HEATING APPLICATIONS

TABLE 2

MODEL	GUIDELINE * MOUNTING HEIGHT ft (m)	MAXIMUM BETWEEN HEATERS ft (m)	DISTANCE – HEATER LONG AXIS PARALLEL TO WALL	
			HORIZONTAL ft (m)	ANGLE MOUNTED
P40U / P40U-I P40U-P / P40U-IP P40U-W / P40U-IW	8 – 18 (2.4 - 5.5)	20 (6)	5 – 12 (5 - 8)	MINIMUM: COMBUSTIBLE CLEARANCE BEHIND (refer to Table 1)

* GUIDELINE MOUNTING HEIGHTS are typical to provide optimum comfort in general space heating applications. Variance from these typical heights can occur in some applications:

- Higher mounting height due to structure or application requirements
- For ‘area’ or ‘spot’ heat, or in areas with greater infiltration rates (near overhead doors, etc) where more intense heat is needed to provide better comfort then lower mounting heights are recommended (minimum 8 ft [2.4 m] mounting height)
- It is recommended that Protective Guard JS-0502-UR-GK be installed on any heater mounted with less than 8 feet from floor to bottom of heater (See Accessories - Page 42)



IMPORTANT: Single or multiple heater placement must be such that continuous operation of heaters will not cause combustible material or materials in storage to reach a temperature in excess of ambient temperature plus 90F° (50C°).

It is the installer's responsibility to ensure that building materials with a low heat tolerance which may degrade at lower temperatures are protected to prevent degradation. Examples of low heat tolerance materials include vinyl siding, fabrics, some plastics, filmy materials, etc.

Refer to "Clearance to Combustibles" information on pages 6 to 8, and Figure 1 and Table 1.

8. HEATER INSTALLATION



Inadequate or improper suspension of the tube heater can result in collapse of the system, property damage, and personal injury or death.

It is the installer's responsibility to ensure that the hardware and structural supports from which the heater is suspended are sound and of adequate strength to support the weight and expansion forces of the heater.



USE CARE & CAUTION WHEN LIFTING HEATER FROM CARTON

1. DO NOT LIFT THE HEATER BY THE REFLECTOR

2. CHAINS PROVIDED ARE TO LIFT HEATER FROM CARTON AND FOR HANDLING PURPOSES ONLY

3. WHEN HANDLING FROM BENEATH HEATER - HANDLE BY TUBE NOT REFLECTOR

4. KEEP THE HEATER HORIZONTAL / LEVEL ALONG ITS LENGTH WHILE HANDLING AND INSTALLING
5. AT LEAST 2 PERSONS ARE REQUIRED TO LIFT AND INSTALL THIS HEATER
6. LIFT SAFELY - LIFT WITH YOUR LEGS AND KEEP BACK STRAIGHT - DO NOT BEND OR TWIST.
7. BEWARE - SHARP EDGES! WEAR PROTECTIVE GLOVES AND CLOTHING WHEN HANDLING

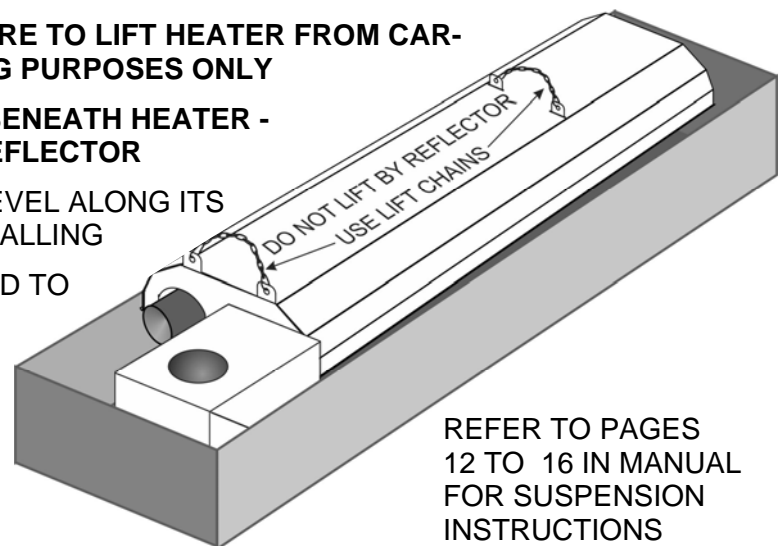

IMPORTANT: FIRST READ and ensure that installation adheres to the information provided on pages 4 to 8 of this manual, and all national and local codes.

Refer to Figures on next pages for figures and dimensions to assist in installation.

1. Establish the location and install the structural mounting supports and any suspension hardware (chain, etc) prior to removing heater from the carton

2. Connect to the structure using mechanically sound means to support the weight. Examples of typical hardware are illustrated in FIGURE 3 below.
 - b) If rigid hardware such as 3/8" threaded rod is used for suspension, swing joints or other means must be provided to allow for system expansion - approximately 1/2 inch for P40U.
3. P40U Models are packaged with the burner assembled to the tube system at the factory. For many applications a pre-assembled heater simplifies installation.
4. However, for applications where there is constrained access to the installation location, or if the tube/reflector system is to be oriented at a 30° mounting angle (see 8. below), we recommend removal of the burner assembly prior to installation of the tube/reflector assembly. Simply disconnect the spark wire from the igniter and remove the four bolts that fasten the burner to the tube flange. Reinstall the burner after the tube system is installed.
5. Survey the available structural supports, considering the system configuration and heat requirements of the area to establish the optimum heater location.
6. Locating a heater directly under joists or beams, and/or installing supplemental steel support rail or angle iron can substantially reduce labor and material costs.
7. The P40U tube system hangers are located 72 inches (183 cm) apart.
8. The tube/reflector system must be level along its length, but can be oriented on the short axis either horizontally, or at an angle up to 30 degrees (vent side of tube must be higher than burner side).
9. When the tube/reflector system is mounted at a 30° angle, the Burner must remain in a horizontal plane. To simplify installation remove burner from tube system prior to installation. The mounting flange on the tube allows for horizontal mounting of the burner when the tube is angled 30° from horizontal.
10. Hardware with a minimum 100 lb. (30 kg) work load must be used at each heater suspension point. A #2 Lion Chain or equivalent is typically used to suspend the heater.
11. The heater must be supported at all four mounting tabs on the hangers. Also install a chain from the eye hook at the upper corner of the burner to maintain system orientation.
12. For seismic and high wind restraint see Sections 8-A & 8-B, page 16.

FIGURE 3 TYPICAL MOUNTING HARDWARE



HOOK OR EYE
BOLT THROUGH
HOLE IN BEAM



BEAM CLAMP
WITH HOOK

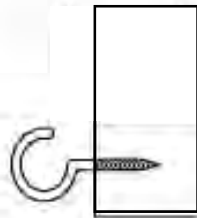

HOOK OR
EYE



PIPE RING
OR CLEVIS
HANGER

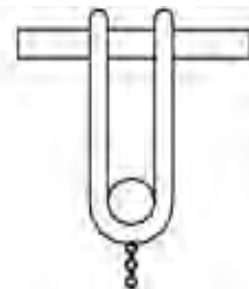

BAR-JOIST
CLAMP



NOTE: It is the installer's responsibility to ensure that mounting hardware and fastening to structure are of sufficient strength and integrity to support the system.

FIGURE 6 P40U MINIMUM CLEARANCES TO COMBUSTIBLES

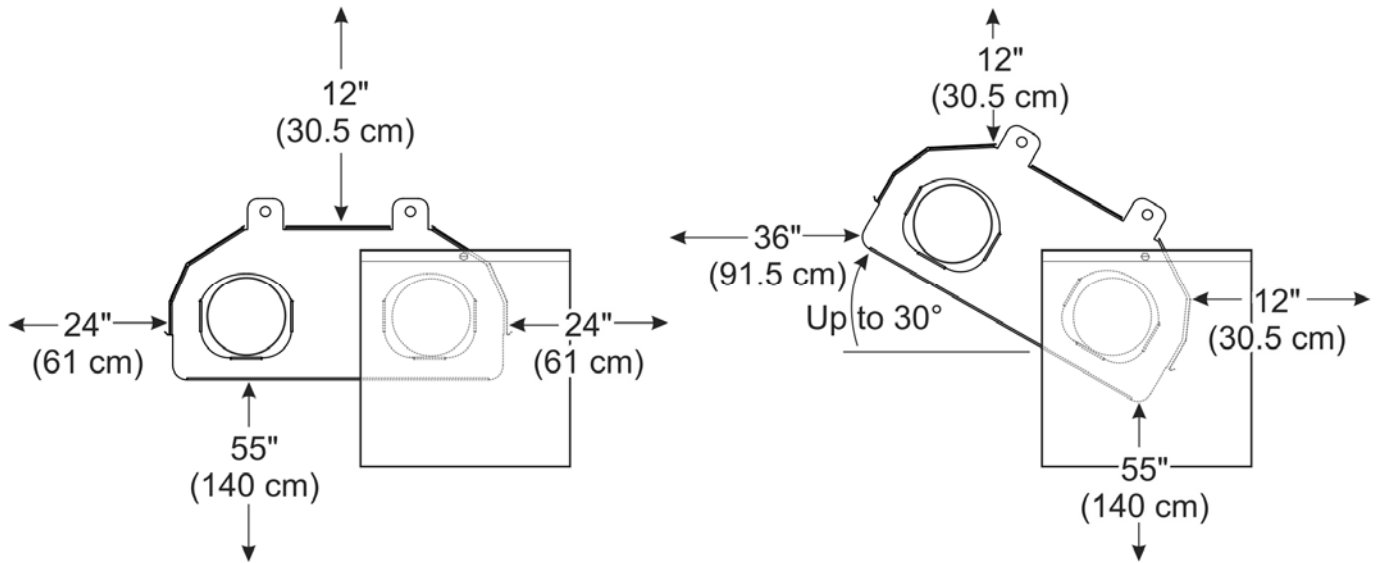

It is the installer’s responsibility to ensure that building materials with a low heat tolerance which may degrade at lower temperatures are protected to prevent degradation. Examples of low heat tolerance materials include vinyl siding, fabrics, some plastics, filmy materials, coatings, laminated surfaces, etc.

Turbulators:

The system is assembled at the factory with turbulators inside the tube. The turbulators serve to increase system efficiency and lower the vent temperature. The turbulators must remain in place inside the tube.

Burner side tube: 36” (914 mm) Turbulator (located at elbow, away from burner)

Vent side tube: 90” (2286 mm) Turbulator

8-A SEISMIC RESTRAINT - LATERAL AND LONGITUDINAL PLANES

FIGURE 7

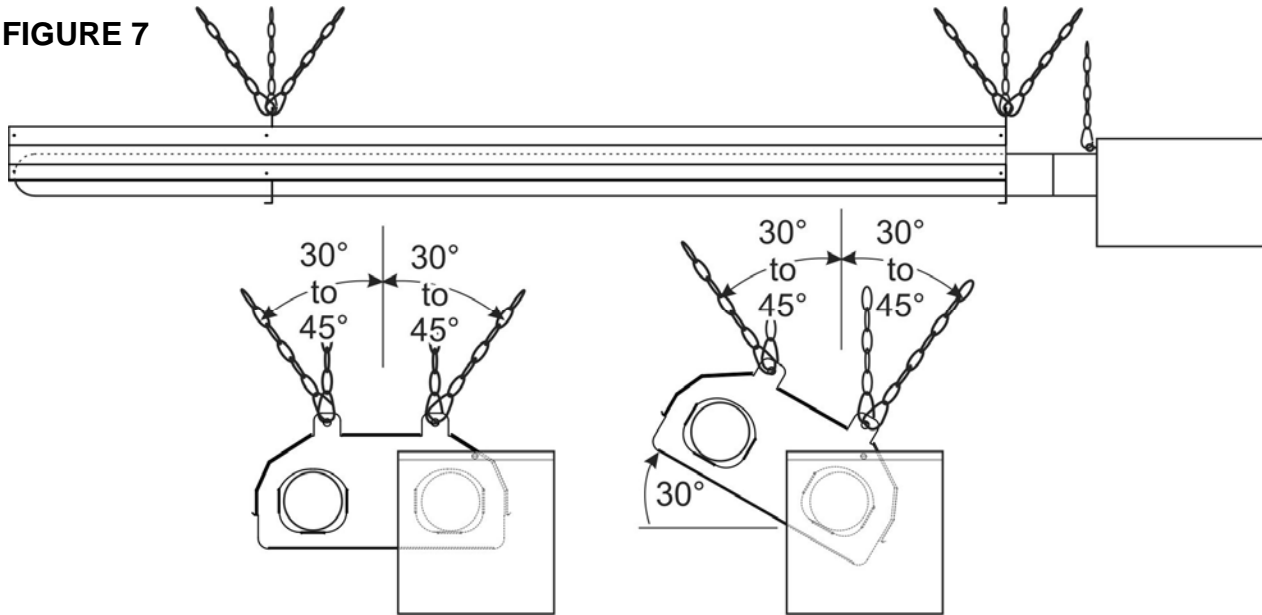

In areas prone to earthquake, or as specified on a project, install lateral and longitudinal seismic restraints as indicated in Figure 11. If the heater location can be impacted by wind (aircraft hangars, etc) refer to High Wind Restraint section **8-B** below.

These instructions indicate attachment of suspension and restraint hardware to the heater. The attachment of suspension hardware to the structure will be as required by site structural conditions, installation codes, and/or local engineering specifications. Other types or systems of restraint that are specified by local or national codes, or by project engineering design specifications may be used .

Schwank / InfraSave offers optional items: #2 Lion Chain 115 lb work load x 200 ft roll (PN: JL-0800-XX); and Safety Snap Hooks (PN: JL-0800-SH = pkg 24; JL-0800-SH-B = pkg 100). All other required seismic mounting hardware is field supplied by the installer.

8-B HIGH WIND RESTRAINT - LATERAL, LONGITUDINAL, AND VERTICAL

In areas with wind conditions that can impact the heater (outdoor, aircraft hangars, etc): in addition to lateral and longitudinal restraint the heater must be restrained from vertical movement.

FIGURE 8

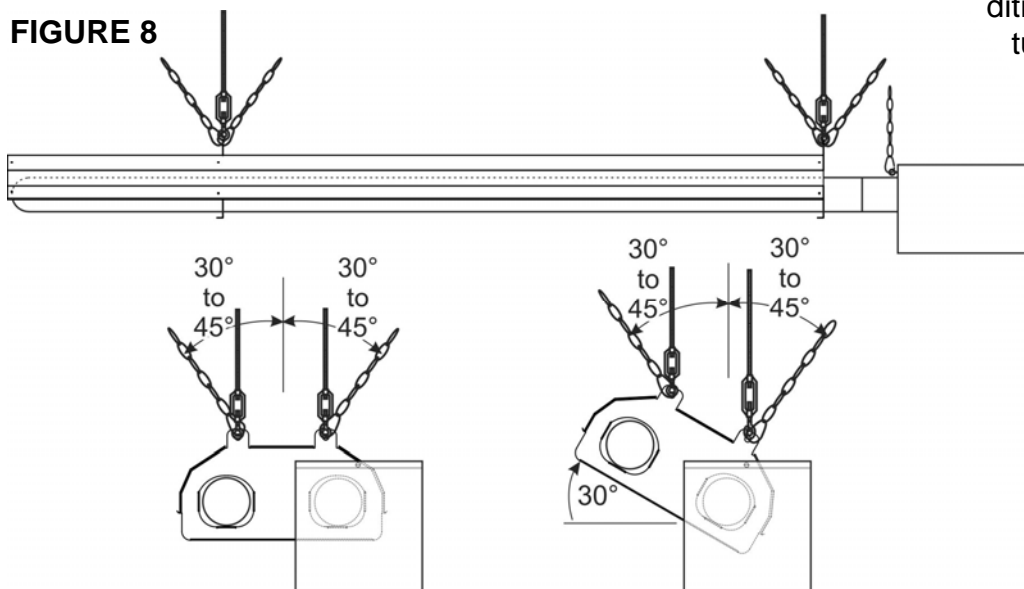

Suspend the heater using 3/8" threaded rod with 3" adjustment turnbuckle at each hanger location to restrain up-and-down movement.



WARNING

9. FLUE VENTING



Inadequate venting of a heater may result in asphyxiation, carbon monoxide poisoning, injury or death. This heater may use a vent connection or indirect venting system to remove products of combustion from the space. Seal all vent connections with high temperature sealant. Venting must be in accordance with all local, state, provincial, and national codes (ANSI Z223.1/NFPA 54 in USA; B149.1 in Canada) and as indicated below in this manual.

THIS TUBE HEATER IS APPROVED FOR VENTING DIRECTLY TO THE OUTSIDE AND UNVENTED (INDIRECT VENTING) APPLICATIONS. THE SYSTEM MUST NOT BE OPERATED WITHIN A NEGATIVE AIR CONDITION UNLESS COMBUSTION AIR IS DUCTED FROM OUTSIDE DIRECTLY TO THE BURNER.

IF NEGATIVE PRESSURE IS EXPERIENCED OR ANTICIPATED, OUTSIDE COMBUSTION AIR MUST BE DUCTED TO THE BLOWER INLET, AND THE 'ATMOSPHERE' PORT (BARB) ON THE BLOCKED FLUE SWITCH MUST BE CONNECTED DIRECTLY TO OUTSIDE AIR USING 1/4" PLASTIC HOSE FROM THE SWITCH TO OUTSIDE OF BUILDING (PLASTIC HOSE IS FIELD SUPPLIED).

UNVENTED (INDIRECT MECHANICAL VENTING SYSTEM)

Indirect venting must not be used if the building experiences a negative air condition. A minimum 10 inch (25 cm) length of single walled vent pipe is to be installed on the swaged end of the last tube before any Tee, Elbow or Termination Cap is fitted.

USA: Natural or mechanical means shall be provided to supply and exhaust at least 4ft³/min/1000Btuh (0.38m³/min/kW) input of installed heaters. Some local codes may require an electrical interlock to a dedicated exhaust fan. Exhaust must be located as high as practicable in the structure above the level of the heater(s). Consult your local code and ANSI Z223.1 latest edition for all venting requirements and practices.

Canada: It is required that the heater(s) be electrically interlocked to dedicated exhaust fan(s) by means of an Air Proving Switch. Exhaust fan(s) must be sized to create 300 cfm (8.5 cu m/min) exhaust for every 100,000 Btuh (30 kW) or any fraction thereof of total input of installed equipment. Exhaust must be located as high as practicable in the structure above the level of the heater(s). Sufficient supply air must be provided. Consult the latest edition of CSA.B149.1 Section 8 for venting system and air supply requirements.

VENTED DIRECTLY TO THE OUTSIDE

It is the sole responsibility of the installer to adhere to all current local codes and/or ANSI Z223.1 / CSA.B149.1 latest editions for all venting requirements, and practices.

It is a normal condition that during heat-up and cool-down a tube heater will expand and contract. Allowances for heater expansion must be made in the venting and combustion air ducting. Improper installation can result in property damage, injury or death.

- All vent pipe and adapters are supplied locally by others
- All venting must be minimum 26 gauge single wall vent pipe of 4" (10 cm) diameter except that portion of vent passing through a combustible wall or roof can be 4" type "B" vent as per CSA International's interim requirement.
- As an Option, two heaters may be vented through an approved common 4" x 4" x 6" Vent Tee (10 x 10 x 15 cm), supplied by the manufacturer. Vent pipe from each heater does not

need to be equidistant to the vent Tee, but must comply to requirements below. The two heaters must be controlled by a single common thermostat or "ON/OFF" switch.

- A minimum 12 inch (30 cm) length of minimum 26 gauge single walled 4" (10 cm) diameter vent pipe is to be installed on the swaged end of the tube before any Tee or Elbow is fitted.
- Seal all vent connections with high temperature sealant. Vent connections must be secured with three (3) #8 sheet metal screws uniformly spaced around the circumference of the vent pipe.
- When the vent pipe passes through a cold or unheated area where the ambient temperature is likely to produce condensation of the flue gases, the vent pipe will be insulated with a suitable material as approved and specified by the insulation manufacturer to withstand temperature up to 460°F (238°C).
- The vent system must **always** be adequately supported to prevent sagging.

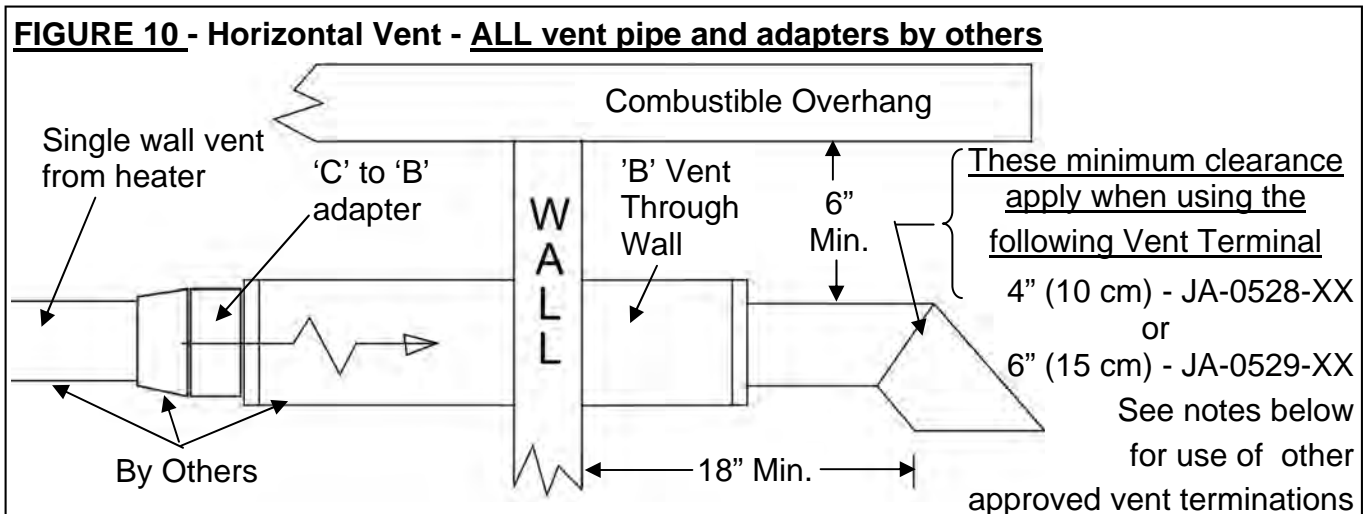
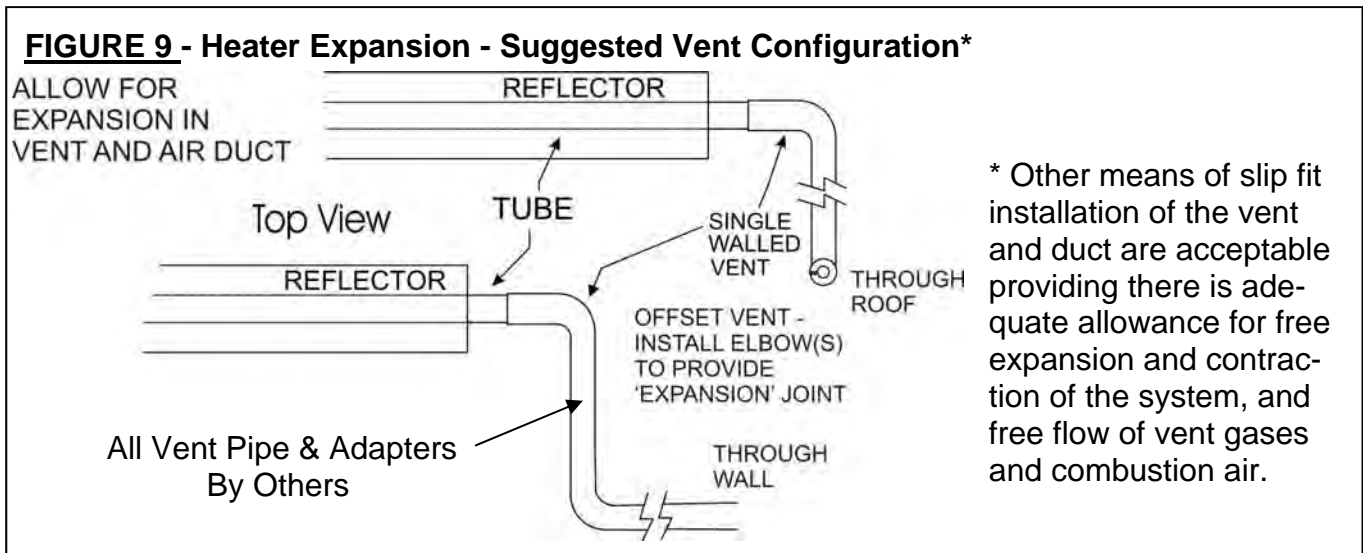

HORIZONTAL VENT THROUGH A SIDE WALL:

- **Maximum allowable flue vent length is equivalent to 20 feet [6.1 m]**
- **A maximum of two 90°elbows (each equivalent 5 ft [1.5 m]) can be installed in the vent**
- The flue vent system must slope downwards approximately 1/4" per foot (63 mm / 300 mm) toward the vent terminal, from the termination of the tube - radiant tube must be level.

- Termination Cap Options:
 - Use the approved 4" (10 cm) (JA-0528-XX) or 6" (15 cm) (JA-0529-XX) horizontal wall vent terminal (see FIGURE 20 for applicable clearances)
 - OR a high-wind termination cap approved by a recognized certification agency (see clearance notes below)
- Install any termination cap a minimum of 18 inches (45 cm) from the outside wall to the inside edge of terminal opening to alleviate back pressure caused by turbulent wind conditions (See Fig. 19). This also ensures flue gases are directed away from the structure to protect building materials from degradation by the exhausted flue gases.
- Termination cap must be installed to prevent blockage by snow and protect building materials from degradation by flue gases.

Clearances for horizontal flue vent :

- Will not terminate less than 1 ft (30 cm) above grade level, unless its location is adjacent to public walkways, then it must not terminate less than 7 ft (2.1m) above the walkway.
- Below an overhang:
 - As indicated in FIGURE 20 for approved terminations: 4" (10 cm) JA-0528-XX or 6" (15 cm) JA-0529-XX
 - For other approved terminations: Will terminate 3 ft (90 cm) or more below a combustible soffit or overhang.

USA specific horizontal vent requirements:

- The vent terminal of a direct-vent appliance with an input between 10,000 Btu/hr (3 kW) and 50,000 Btu/hr (14.7kW) shall be installed with a 9 inch (230mm) vent termination clearance from any air opening into a building, and an appliance with an input over 50,000 Btu/hr (14.7kW) shall have at least a 12inch (300mm) vent termination clearance. The bottom of the vent terminal and the air intake shall be located at least 12inches (300mm) above grade.
- A horizontal vent will not terminate:
 - Less than 3 ft (90 cm) above a mechanical air inlet located within 10 ft (3.1 m)
 - Less than 4 ft (1.2 m) below, 4 ft (1.2 m) horizontally from, and 1 ft (0.3 m) above any window or door that opens, or gravity air inlet to a building
 - Less than 4 ft (1.2 m) horizontal clearance from gas and electric meters, regulators and relief equipment

CANADA specific horizontal vent requirements:

- A horizontal vent will not terminate:
 - Within 6 ft (1.8 m) of a mechanical air supply inlet to any building.
 - Above a gas utility meter and regulator assembly within 3 ft (0.9 m) horizontally of the vertical centerline of the regulator vent outlet to a maximum vertical distance of 15 ft (4.5 m).
 - Within 3 ft (90 cm) of any gas pressure regulator vent outlet
 - Within the following distances of a window or door that can be opened in any building, of any non-mechanical air-supply inlet to any building, or of the combustion air inlet of any other appliance:
 - 12 inches (30 cm) for inputs up to and including 100,000 Btuh (30 kW)
 - 3 ft (90 cm) for inputs exceeding 100,000 Btuh (30 kW)

VERTICAL VENT THROUGH THE ROOF:

It is the sole responsibility of the installer to adhere to all current local codes and/or ANSI Z223.1 / CSA.B149.1 latest editions for all venting requirements, and practices.

- Use an approved 'B-vent' termination cap as supplied by the manufacturer of the approved 'B-vent'.
- When vent and combustion air are taken through the roof, the exhaust vent should always terminate higher than the combustion air intake, to prevent recycling the products of combustion back into the heater.
- **Maximum allowable 4" [100 mm] diameter vent length equivalent to 20 feet [6 m]**
- **A maximum of three 90° elbows (each equivalent 5 ft) can be installed in a vertical vent**

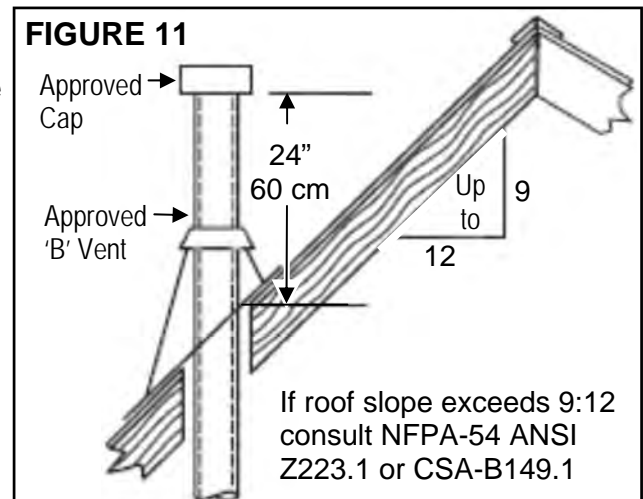

10. COMBUSTION AIR DUCTING

Whenever possible, locate the air intake and vent terminals in a common pressure area. For example on a common wall, or commonly through the roof. Depending upon wind conditions, terminations located in uncommon pressure areas can create intermittent operation problems.

Combustion Air Duct can be 4", or 5" diameter (reduce to 4" only at connection to blower collar).

4" Dia. Air Duct: Maximum combined total length of flue vent plus combustion air duct equivalent to 35 feet, and neither the 4" diameter vent or duct component can exceed 20 feet.

5" Dia. Air Duct: Maximum combined total length of flue vent plus combustion air duct equivalent to 50 feet. The 4" diameter vent cannot exceed 20 feet; the 5" diameter air duct cannot exceed 35 feet.

- Total vent and duct length is reduced by five feet for every 90° elbow installed in the vent and/or duct system
- Exceeding the allowable lengths noted above may cause unreliable operation, create condensation or soot conditions, and will void CSA Certification and the heater warranty.

An opening is located on the top surface of the burner housing for combustion air. Ensure adequate clearance around this opening to allow sufficient combustion air supply to the heater. Combustion air duct must be constructed of noncombustible material.

When a tube heater is operated in a negative air condition, or air-borne dust or contaminants are present as in woodworking and welding shops, air for combustion must be ducted from outside the negative or contaminated area to the 4 inch (10 cm) diameter intake collar supplied on the blower. See notes above for maximum combined equivalent vent and duct length.

The air intake will not be located less than:

- Three feet above grade
- Twelve inches from flue vent terminal of any heater with input up to 100,000 Btu/hr
- Three feet from flue vent terminal of any heater over 100,000 Btu/hr

Do not install filters on the combustion air intake. Ensure adequate clearance around the air intake to allow sufficient combustion air supply to the heater.

continued ...

Optional 4 inch intake terminals are available for this heater:

- Part number: JS-0532-VC Wall mount, bird-screened fresh air intake duct hood
- Part number: JS-0530-XX Roof cap

Ensure adequate clearance around the air intake to allow sufficient combustion air supply to the heater. If drawing fresh air from outside, it is recommended that any single wall pipe containing cold air be insulated to prevent or reduce condensation on the pipe.

Do not use flexible dryer hose or any 'soft wall' tubing for air inlet duct, the soft corrugated sides of this tubing restrict air flow. A good quality industry approved insulated flex is allowed.

CAUTION:



In locations where chlorinated Hydrocarbons are in use, such as Trichloroethylene or Chloroethylene Nu it is essential that combustion air be brought in from a non-contaminated area. Burning the fumes from these gases will create Hydrochloric acid fumes, which are detrimental to humans, equipment and buildings. Typical sources of other contaminants are paint removers, paints, refrigerants, solvents, adhesives, degreasers, lubricants, pesticides, etc.



The heater manufacturer cannot anticipate all chemical compositions and types of potential contaminants at project sites. Confer with project site safety, health and engineering staff and/or local authorities having jurisdiction such as the Fire Marshall and Department of Labor for possible contaminants and any conflict with the installation of hot surface heating equipment.

11. GAS SUPPLY - GAS CONNECTION - HEATER EXPANSION



CAUTION: Compensation for expansion of gas supply pipe and radiant tube heater must be provided. All piping must conform to local and national codes.

This heater will expand up to 1 inch (2.5 cm) in length during operation. To allow for heater expansion the gas supply must be connected using the flexible gas connector that is supplied with this model heater:

- **In the USA:** a 1/2" x 24" stainless steel Flexible Gas Connector certified for use on an infrared radiant tube heater (ANSI Z21.24 CSA 6.10);
- **in CANADA:** a 1/2" x 36" (± 6 ") Type 1 Gas Hose Connector (CAN/CGA 8.1).



IMPORTANT: See page 24: Orientation of connector between heater and gas supply.



TEST FOR LEAKS: All gas piping and connections must be tested for leaks after the installation is completed.

Apply soap suds solution to all connections and joints and if bubbles appear, leaks have been detected and must be corrected.



DO NOT USE A MATCH OR OPEN FLAME OF ANY KIND TO TEST FOR LEAKS. NEVER OPERATE THE HEATER WITH LEAKING CONNECTIONS.

Provide a 1/8 in (3.2 mm) NPT plugged tapping, accessible for test gauge connection, immediately upstream of the gas supply connection to the heater.

The supply system should be checked first with heater turned "OFF" followed by another check with heater turned "ON".



DO NOT use pressure greater than 1/2 psig to pressure check the heater. During any pressure testing of the gas piping system each heater must be isolated from the piping system by closing its individual manual shut off valve (field supplied) .

IMPORTANT: Minimum supply line pressure at the inlet to the heater regulator must not be lower than 5.0 inches of water column pressure for natural gas. The supply gas pressure must be checked with all heaters in operation.

Installation of a gas line (trap) “drip leg” is required at the inlet connection tee following the pipe drop to the heater. Failure to provide a “drip leg” could result in condensation and foreign matter passing into the gas valve. Failure to install a “drip leg” in the gas line can cause property damage, injury or death and will void the heater warranty.

GAS TYPE	LINE PRESSURE INCHES WATER COLUMN		MANIFOLD PRESSURE (tap at gas valve outlet) INCHES WATER COLUMN
	MINIMUM	MAXIMUM	
Natural Gas	5.0	14.0	3.5
LP Gas	11.0	14.0	10.0

NOTE: Access to the manifold pressure test port is located on the top of the valve. A 3/16" Allen Key is required. A **manometer** should be used to check the manifold pressure. Gauges which measure in ounces or PSI are not accurate enough to measure or set the pressure.

ORIENTATION OF FLEXIBLE GAS CONNECTOR

The flexible gas connector **MUST** be installed in the orientation shown below as required by national installation codes and by the certification standard of this heater. This orientation protects the flexible gas connector from damage due to movement during heater expansion.

It is the responsibility of the installer to ensure correct installation of the flexible gas connector.

FIGURE 12

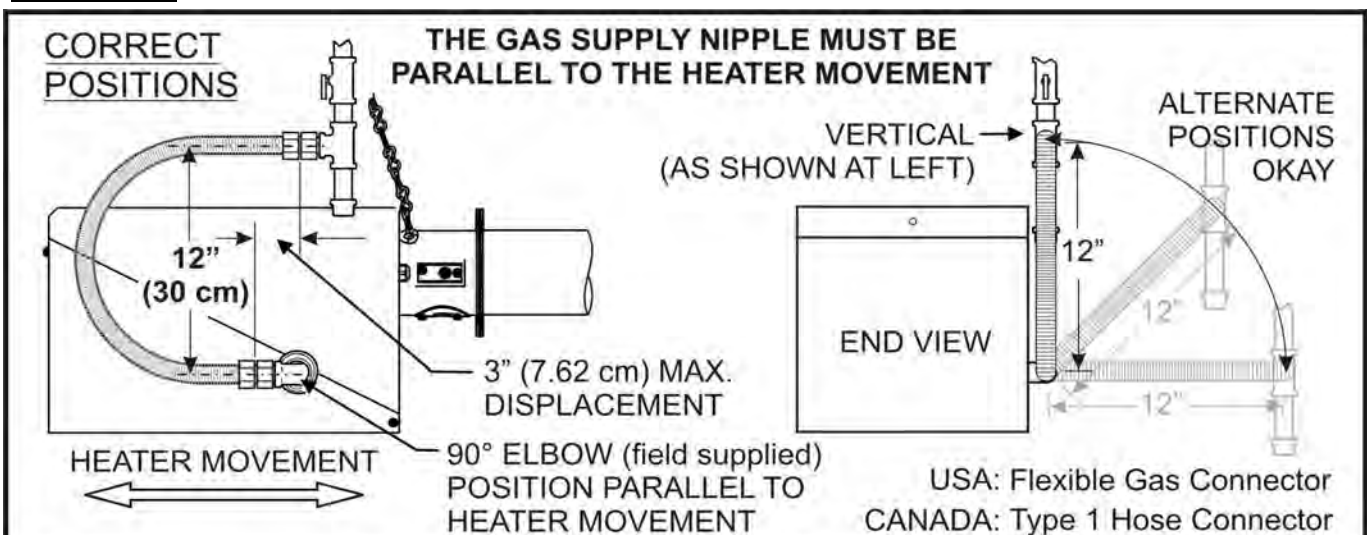

WARNING: CONNECTOR MUST BE INSTALLED IN “C” CONFIGURATION. USE ONLY THE CONNECTOR OF PROPER LENGTH AND NOMINAL ID THAT IS FURNISHED WITH THIS HEATER - **SEE ALSO NEXT PAGE**

Orientation of Flexible Gas Connector (continued)

FIGURE 13

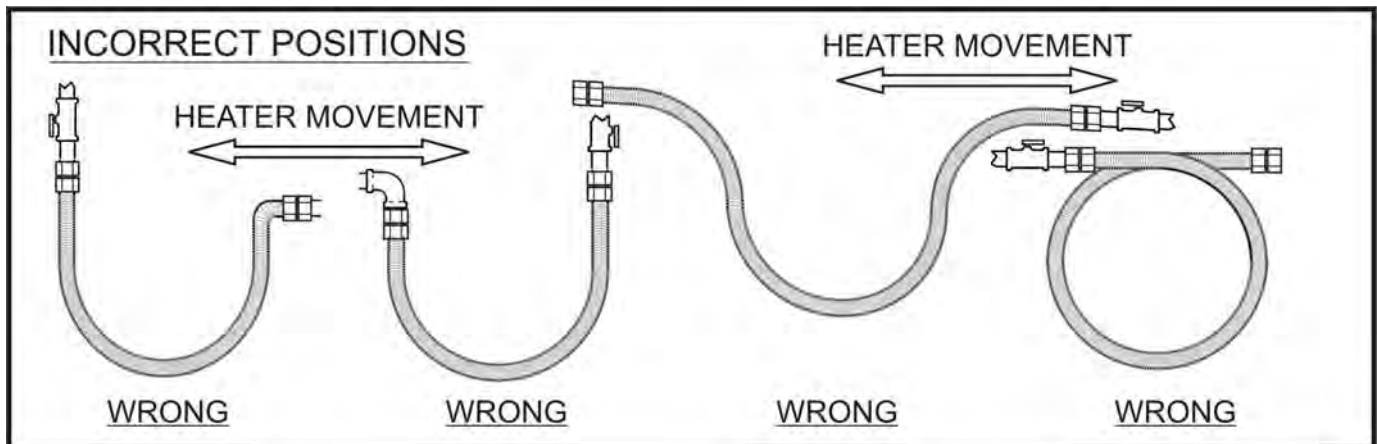

12. GAS CONVERSION



WARNING: Gas conversion must only be performed by a trained gas service technician.

Do not convert heater to alternate gas without using one of the kits listed below. Property damage, injury or death could result.

Standard production of this model heater is for use with natural gas. Field conversion between Natural Gas and Propane Gas can be accomplished using field conversion kits available from your local Schwank or InfraSave supplier:

- Part number: JS-0555-XB P40U* - Natural Gas to Propane Gas Conversion Kit
- Part number: JS-0555-XA P40U* - Propane Gas to Natural Gas Conversion Kit

* All models: Schwank P40U, P40U-P, P40U-W; InfraSave P40U-I, P40U-IP, P40U-IW

13. ELECTRICAL AND THERMOSTAT WIRING (WIRING DIAGRAMS PAGE 26 & 27)



NOTICE

The heater must be electrically grounded in accordance with the National Electrical Code. ANSI / NFPA 70 or current Canadian Electrical code CSA C22.1. Maximum power flow for internal 24V burner components is 21VA.

Appliance and control wiring must be in accordance with all applicable local codes. The total load of all heaters must be considered in determining the required contact rating of the controlling thermostat or switch. Each tube heater requires 120V, 60 HZ electrical power sized for 145VA. Maximum power flow for internal 24V burner components is 21VA.

The ignition control includes a 24V/120V relay switch that provides a 45 second post-purge of the system. **A 24V Thermostat, TruTemp Thermostat, or 24V controller signal must be used for the post-purge feature to function.** A line voltage Thermostat or an "ON/OFF" switch will disable the post-purge feature.

A maximum night set-back of 9°F (5°C) is recommended for optimum economy and comfort. To maintain satisfactory comfort levels do not turn off the heating system over night/weekends.

14. HIGH ALTITUDE INSTALLATIONS - *also refer to chart in Section 28*

When installed above the altitude stipulated below for the USA or Canada, the input must be de-rated by 4% for each 1000 ft above the altitude listed . **If your local utility supplies gas with a de-rated heat content, no orifice change is required in the heater** . If the gas supply is not de-rated, the orifice must be changed according to the chart in Section 28. Check with your local utility regarding the gas supply and the de-rating of this appliance. Maintain gas supply pressures indicated in Table 4, page 33.

USA: The factory installed orifice for this appliance is approved for altitudes zero to 2000 feet above sea level. When installed above 2000 feet, **refer to Section 28.**

Canada: The factory installed orifice for this appliance is approved for altitudes zero to 4500 feet above sea level. When installed above 4500 feet, **refer to Section 28.**

15. LIGHTING INSTRUCTIONS

Refer to the lighting instructions label on the outside of the burner housing. If the unit locks out on safety, main power to the unit must be manually interrupted for a 30 second reset period before the heater can be restarted.

NOTE: *On initial installation, the unit may lock out on safety owing to the length of time required to bleed air from the gas piping system.*

16. RECOMMENDED MAINTENANCE

Improper adjustment, alteration, service or maintenance can cause property damage, injury or death. This heater must be installed and serviced only by a trained gas service technician.



1. Inspect the entire heater system, venting, and gas supply connections at least annually prior to the heating season. Replace worn parts and repair deficiencies.
2. Check the inlet air opening and the blower periodically, cleaning off any lint or foreign matter. It is important that the flow of combustion and ventilation air must not be obstructed.
3. Lubricate Blower motor, by adding several drops of oil to oil ports located on the left hand side of the motor.

THE TUBE HEATER BURNER IS COMPLETELY FACTORY ASSEMBLED AND TESTED. ANY ALTERATION VOIDS THE CSA CERTIFICATION AND MANUFACTURER'S WARRANTY. FOR ADDITIONAL INFORMATION, CONTACT YOUR LOCAL DISTRIBUTOR OR THE MANUFACTURER.

**17. FENWAL DSI: WIRING DIAGRAM: 24V OR 120 VOLT THERMOSTAT OPERATION
SINGLE HEATER PER THERMOSTAT** (Multiple Heaters per Thermostat—next page)

NOTE: Models produced with FENWAL DSI have model designation: P40U-F & P40U-IF

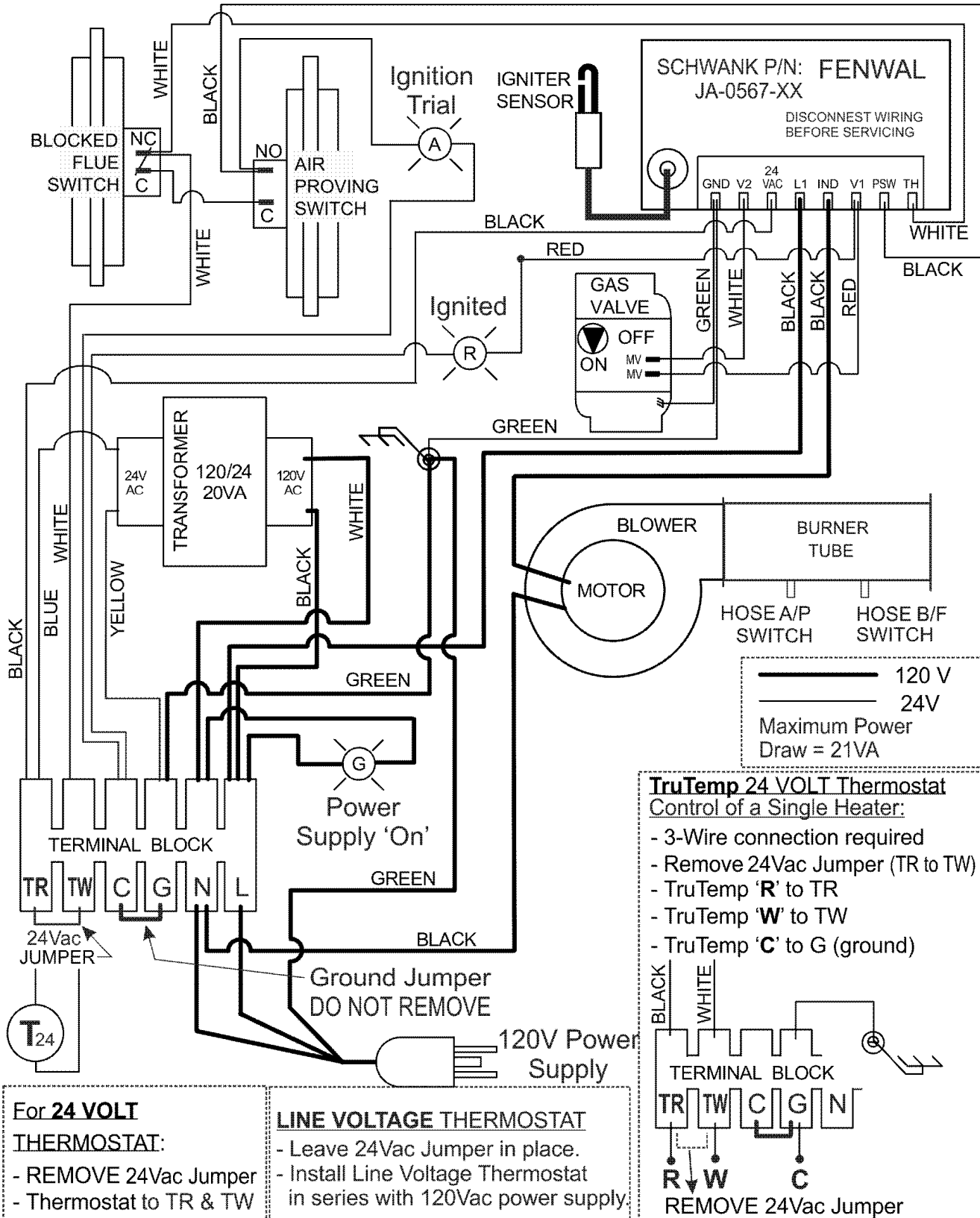

OTHER DSI's: MODELS P40U-P,-W - MICRO 50N - PAGE 31; HONEYWELL S87J - PAGES 59 - 61

18. MULTIPLE TUBE HEATERS per THERMOSTAT (ALL DSI TYPES)

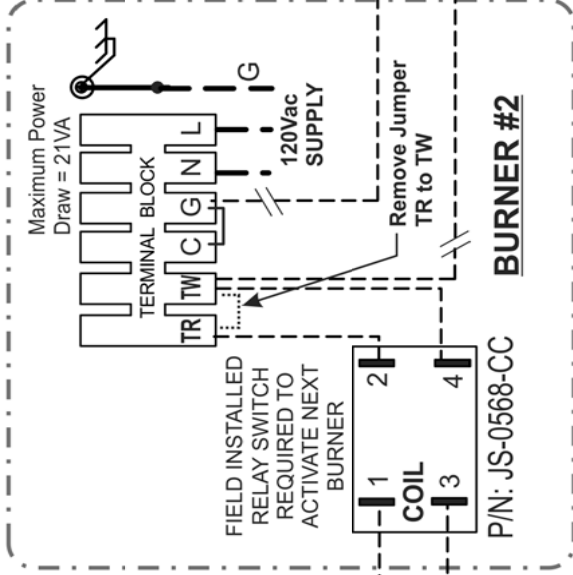
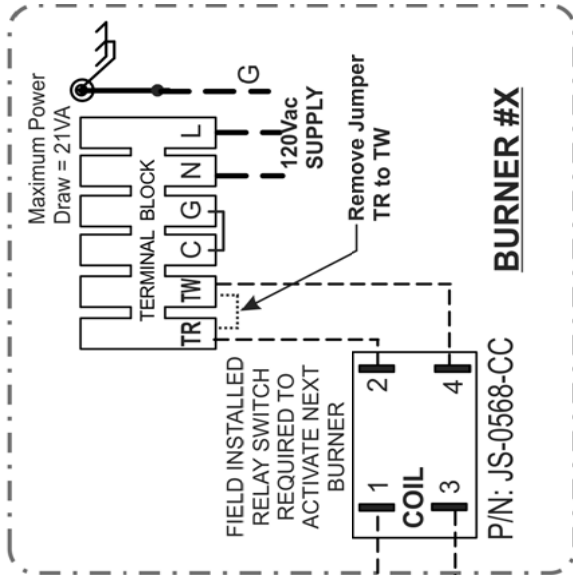
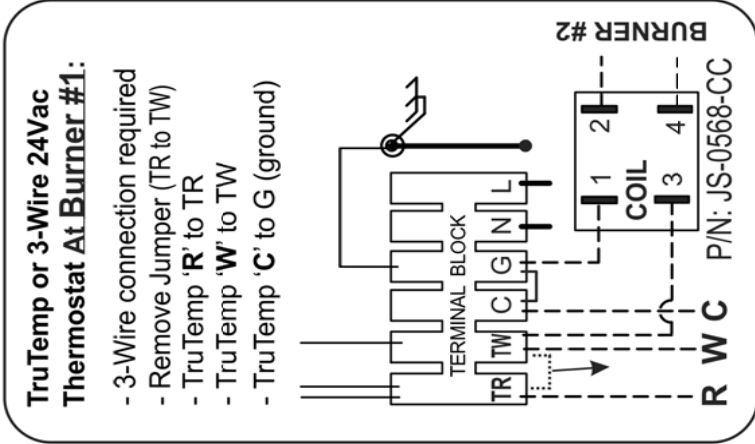
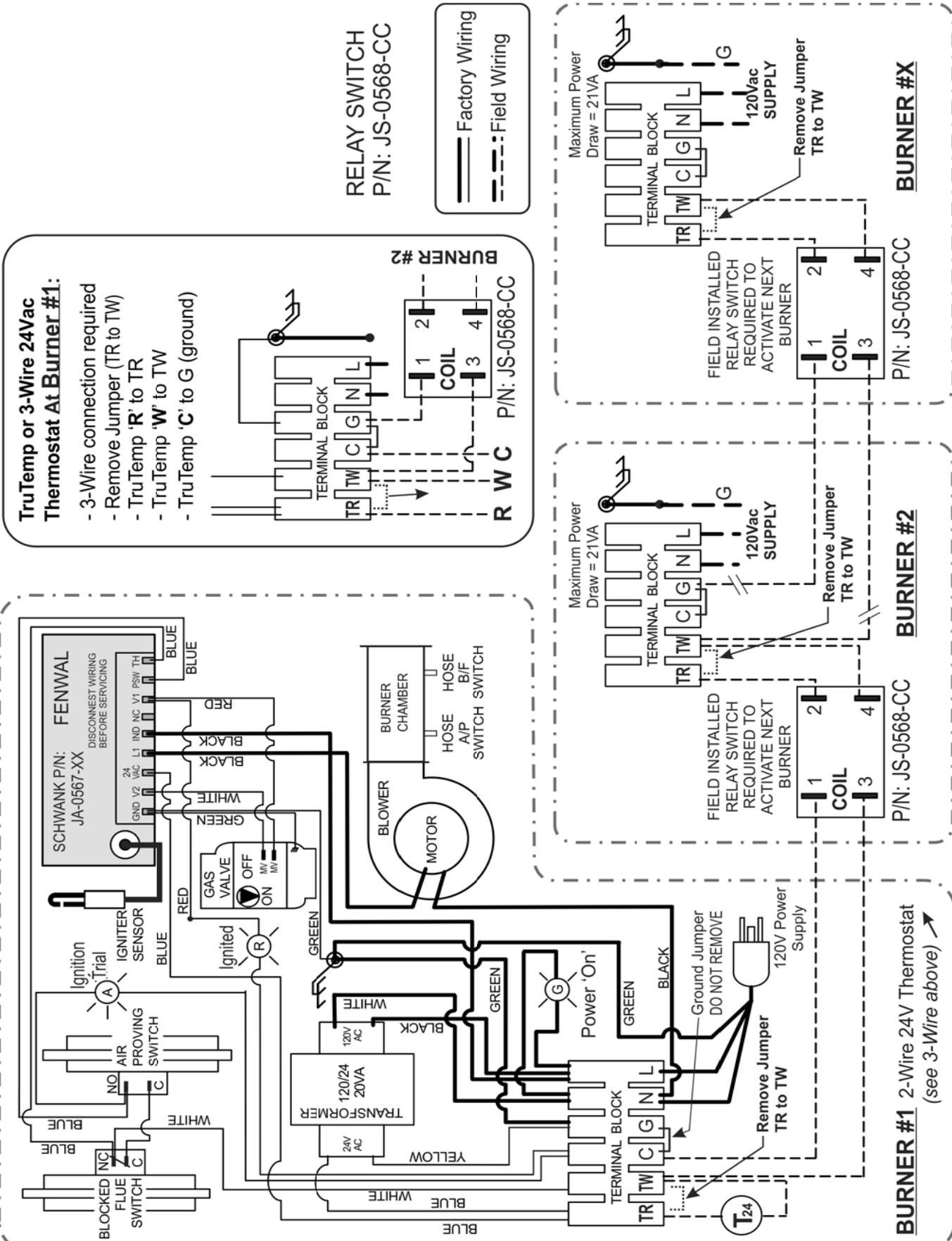

19. FENWAL DSI: SEQUENCE OF OPERATION / FLAME RECOVERY / SAFETY LOCKOUT

Power Up / Stand By

Upon applying 24 volts power to 24VAC, the control will reset, perform a self check routine, initiate full time flame sensing, flash the diagnostic LED for up to four seconds, and enter the thermostat scan state.

Heat Mode

When a call for heat is received from the thermostat supplying 24 volts to TH, the control checks the pressure switch for normally open contacts. The combustion blower is then energized and once the pressure switch contacts close, a 30 second purge delay begins. Following the purge period the gas valve is energized and spark commences for the 15 second trial for ignition.

When flame is detected during the trial for ignition, spark is shutoff immediately and the gas valve combustion blower remains energized. The thermostat, pressure switch, and main burner flame are constantly monitored to assure the system continues to operate properly. When the thermostat is satisfied and the demand for heat ends, the main valve is de-energized immediately, the control senses the loss of flame signal and initiates a 30 second post-purge period before de-energizing the combustion blower.

Failure to Light - Lockout (THREE TRIAL MODEL)

This three-try control will attempt two additional ignition trials with a 30 second inter-purge between trials, before going into 'soft' lockout. The valve relay will be de-energized immediately, and the combustion blower will be turned off following the 30 second post purge period.

If the thermostat continues to call for heat after one hour the control will automatically reset and attempt to ignite the burner again (three trials).

At any time less than the 1 hour auto-reset, recovery from lockout requires a manual reset by either resetting the thermostat or removing 24 volts for a period of 5 seconds.

Flame Failure - Re-Ignition

If the established flame signal is lost while the burner is operating, the control will respond within 0.8 seconds. The HV spark will be energized for a trial ignition period in an attempt to relight the burner. If the burner does not light the control will de-energize the gas valve. Two more attempts will be made to relight the burner. If the burner does not relight the control will go into 'soft' lockout as noted above in "Failure to Light". If flame is re-established, normal operation resumes.

Combustion Airflow Problems -Lockout

Combustion air flow is continually monitored during an ignition sequence by the air flow switch (PSW). If during the initial call for heat the pressure contacts are in the closed position for 30 seconds without an output to the Combustion Blower, an air flow fault will be declared and the control will remain in this mode with the combustion blower off.

If the air flow switch remains open for more than 30 seconds after the combustion blower output (L1 & IND) is energized, an air flow fault will be declared and the control will stay in this mode with the combustion blower on, waiting for the air flow switch to close.

When proper air flow is detected from the air flow switch input (PSW) the control begins the pre-purge period followed with a 15 second ignition sequence.

If the air flow signal is lost while the burner is firing, the control will immediately de-energize the gas valve and the combustion blower will remain on. If the call for heat remains, the control will wait for proper air flow to return. If proper air flow is not detected after 30 seconds an air flow fault signal will be declared. If proper air flow is detected at any time, a normal sequence will begin with the pre-purge period.

Flame Fault

If at any time the main valve fails to close completely and maintains a flame, the full time flame sense circuit will detect it and energize the combustion blower. Should the main valve later close completely removing the flame signal, the combustion blower will power off following the optional post purge period.

Fault Conditions

The LED will flash on for 1/4 second, then off for 1/4 second during a fault condition. The pause between fault codes is 3 seconds.

Error Mode	LED Indication
Internal Control Failure	Steady on
Air Flow Fault	1 flash
Flame with No Call for heat	2 flashes
Ignition Lockout	3 flashes

MOUNTING AND WIRING

The Series 35-61 is not position sensitive and can be mounted vertically or horizontally. The case may be mounted on any surface with #6 sheet metal screws. All wiring must be done in accordance with local and national electrical code. Refer to wire diagram page 35 when connecting the Series 35-61 to other components in the burner.



The Series 35-61 DSI Control uses voltages of shock hazard potential. Wiring and initial operation must be done by a qualified service technician. The control must be secured in an area that will experience a minimum of vibration and remain below the operating temperature of 160°F. All connections should be made with UL approved 105°C rated 18 gauge, stranded, .054 thick insulated wire. Refer to wire diagram page 35 when connecting the Series 35-61 to other components in the burner.

TERMINAL	SPADE	DESIGNATION
TH	1/4"	Thermostat Input
PSW	1/4"	Pressure Switch Input
V1	1/8"	Valve Power (MV)
IND	1/4"	Inducer Blower Output
NC	-	Alarm (Not used)
L1	1/4"	120/240 VAC Input (Hot)
24 VAC	1/4"	24 VAC Supply to Processor
V2	1/8"	Valve (MV)
GND	1/8"	Valve & System Ground
Spark	1/4"	Spark & Local Flame Sense

CAUTION:

Label all wires prior to disconnection when servicing controls. Wiring errors can cause improper and dangerous operation. A functional checkout of a replacement control is recommended.

PROPER ELECTRODE LOCATION

Proper location of the electrode assembly is important for optimum system performance. The electrode assembly should be located so that the spark gap is inside the flame envelope about 1 inch (2.5 cm) from the base of the flame at the burner cup.

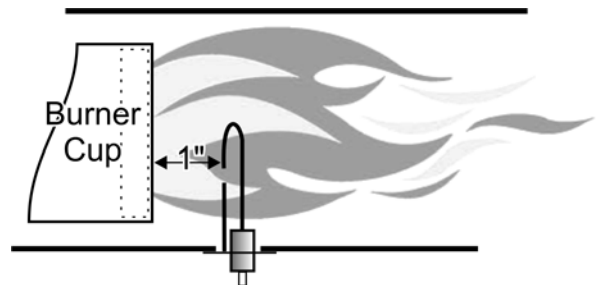

Electrodes should have a gap spacing of 3/16" (0.188" ± 0.031" or 4.76 mm ± 0.81 mm). If this spacing is not correct, the assembly must be adjusted or replaced. DO NOT adjust the curved igniter/sensor prong. Adjust/bend only the ground prong (**More Detail Page 32**).

SERVICE CHECKS

Flame current passes through the flame from the sensor to ground. The minimum flame current necessary to keep the system from lockout is 0.7 microamps. To measure flame current, connect an analog DC microammeter to the FC- FC+ terminals per figure at right.

Meter should read 0.7 μ A or higher. If the meter reads below "0" on scale, meter leads are reversed. Disconnect power and reconnect meter leads for proper polarity.

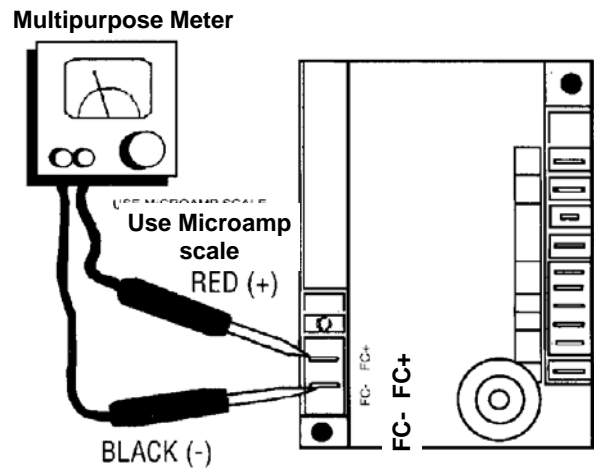

TROUBLESHOOTING - FENWAL DSI

(also see *Heater Troubleshooting Page 33*)

SYMPTOM	RECOMMENDED ACTION(S)
1. Dead	A. Miswired - check electrical supply (120Vac \pm 5%) B. Transformer bad (24Vac \pm 10%) C. Fuse/Circuit breaker bad D. Bad control (check LED for steady on)
2. Thermostat on - no blower output	A. Miswired B. Bad thermostat no voltage @ terminal W C. Bad control (check LED for steady on)
3. Pressure switch input okay, but no Trial-for-Ignition after purge delay	A. Miswired (check PSW terminal voltage: 24Vac \pm 10%) B. Flame sense problem (existing flame: check LED - 2 flashes) C. Bad control (check line voltage between L1 & IND)
4. Valve on, no spark	A. Shorted electrode B. Open HV cable C. Bad control
5. Spark on, no valve	A. Valve coil open B. Open valve wire C. Bad control (check 24Vac voltage between V1 & V2)
6. Flame ok during TFI, no flame sense (after TFI)	A. Bad electrode B. Bad HV igniter wire C. Poor ground at burner D. Poor flame (check flame current)

20. OUTDOOR MODELS: P40U-P, P40U-W WIRING DIAGRAM: 24V OR 120 VOLT THERMOSTAT
SINGLE HEATER PER THERMOSTAT

Models P40U, -I Page 25
 Multiple Heaters/Thermostat ... Page 26

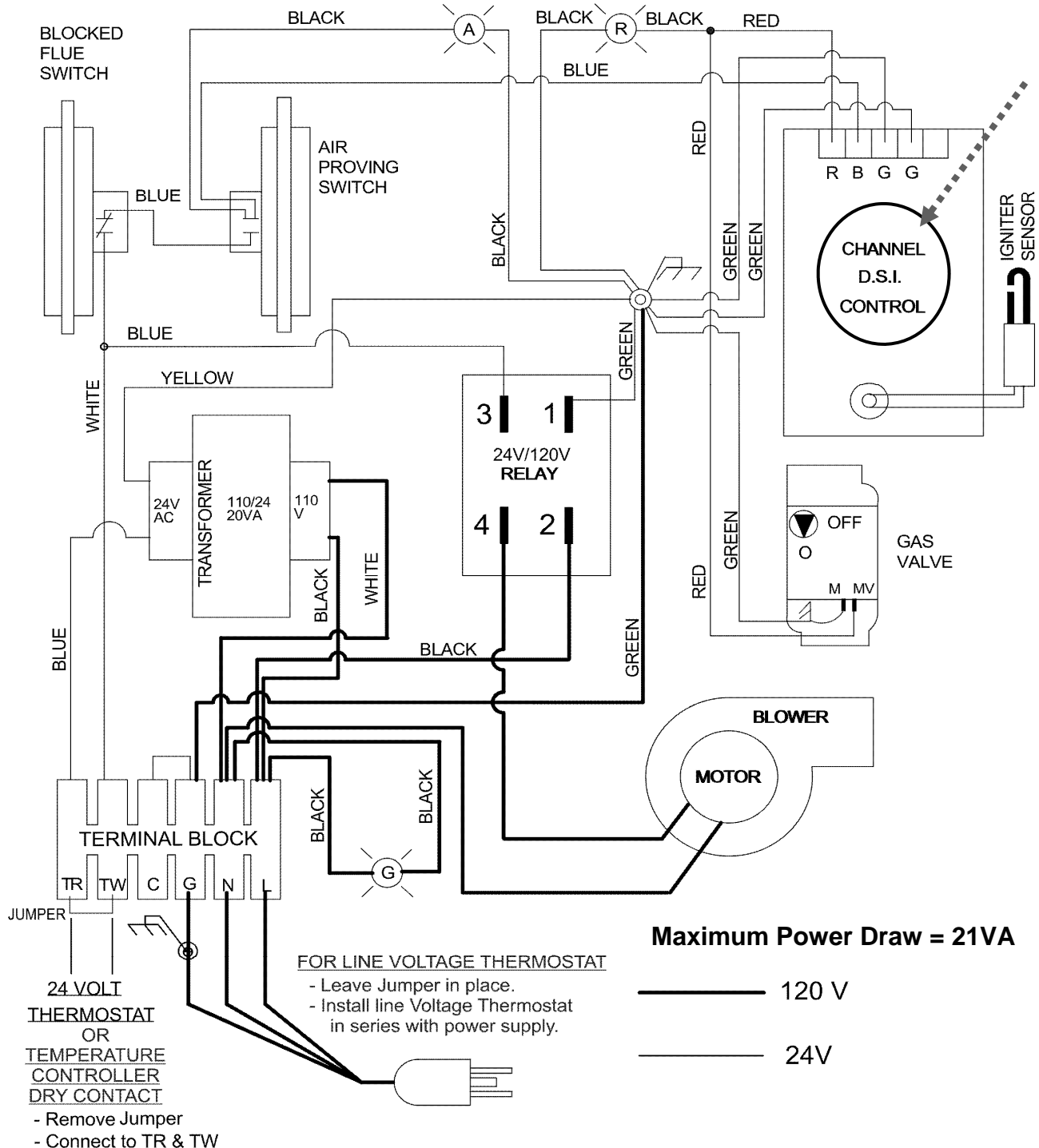

Each tube heater requires 120V, 60 HZ electrical power sized for 145VA. The heater includes a 24V/120V relay switch . Maximum power draw for internal 24V burner components is 21VA.

The heater must be electrically grounded in accordance with the National Electrical Code. ANSI / NFPA 70 or current Canadian Electrical code CSA C22.1.

A maximum night set-back of 9°F (5°C) is recommended for optimum economy and comfort. To maintain satisfactory comfort levels do not turn off the heating system over night/weekends.

21. P40U-P (-IP), P40U-W (-IW) SEQUENCE OF OPERATION GASLITER 50N (DSI)

The Gasliter 50N is a three trial ignition control module with a 30 minute soft lockout/reset. It is powered by a 24v transformer that is activated when the thermostat calls for heat. On every call for heat the Gasliter 50N will delay start-up to provide a 30 second system pre-purge. When the Gasliter 50N is activated by a thermostat or call for heat an internal transformer provides power to the electronic generator circuit for Spark Ignition and the retrial/safety lockout timing begins. At the same time, the Gasliter 50N opens the gas control valve allowing gas to flow to the main Burner.

The Gasliter 50N Control Module performs the following basic functions:

- Provides a 30 second system pre-purge
- Supplies power to the electronic pulse-generator circuit for the Spark Igniter (30,000 volts open circuit).
- Allows up to three 20 second Trials For Ignition (TFI) before a 'soft' system safety lockout of 30 minutes occurs.
- Three time TFI and soft 30 minute lockout repeat
- Senses the Burner flame for safe lighting
- Shuts off the spark after the Burner is lit.

Burner with direct spark ignition, sequence is as follows :

- 1a. **Line Voltage Thermostat:** Upon a call for heat by the line voltage Thermostat or "ON/OFF" switch, the Blower and the 120/24 volt Transformer are powered simultaneously with 115 volts. *continue to 2.*
- 1b. **24 Volt Thermostat:** 120 volt supply to heater powers the 120v/24v Transformer and the 120V side of the Blower switching relay simultaneously. A call for heat by the 24 volt Thermostat energizes the 24 volt control circuit and the 24v/120 volt relay powering the Blower.
2. The 24 volt control circuit powers the DSI control in series through the normally open Air Pressure Switch (APS) and the normally closed Blocked Flue Switch (BFS).
3. The Blower creates a positive pressure and closes a normally open contact inside the Air Proving Switch (APS).
4. Provided there is no blockage in the system (tube and vent), the Blocked Flue Switch remains in a normally closed position.
5. 24 volts supplied to the DSI control initiates the 30 second pre-purge cycle.
6. After completing the 30 second pre-purge cycle the DSI control generates high voltage to the Spark Igniter, and 24 volts to energize the Gas Valve.
7. The Burner will light and establish a steady flame.
8. Once the flame sensor determines there is a steady flame established, with a minimum flame signal of 1.5 μ A the spark igniter is then de-energized.
9. In the event ignition does not occur, the DSI control will retry the ignition sequence up to an additional two trials. If ignition does not occur after the third ignition trial, the system will enter a 30 minute 'soft' lock-out. This will reset the ignition module and the operating sequence will restart at step #1 after the 30 minute lock-out period.
10. If there is a loss of flame during the run mode, the unit will energize the spark within 0.8 seconds and perform a T.F.I., without the gas valve being closed first, this is called Spark Restoration. If a flame is not established during Spark Restoration the unit will repeat the process in step number 9 (above).

22. IGNITION CONTROL: MODELS P40U-P, -W (-IP, -IW) - GASLITER MICRO 50N

The MICRO 50N is a microprocessor-based DSI (Direct Spark Ignition) control which continuously monitors the burner to ensure safe operation under all conditions. The MICRO 50N DSI Control includes specified purge and trial times, multiple ignition attempts, a diagnostic alarm output, and automatic recycle on soft lockout. The polyurethane encapsulated circuit board is suitable for damp and wet environments. The MICRO 50N uses electrode flame sensing.

SPECIFICATIONS

Operating Voltage:	24 VAC, 50/60Hz
Power Consumption:	200mA maximum, exclusive of valve/alarm loads
High Voltage:	15kV minimum with 50 pF load
Spark Gap:	0.150 inches +/- 0.050 inches, 3.8 mm +/- 1.2 mm
Spark Rate:	60 sparks per second
Ignition Trials:	Three (3)
Prepurge:	30 seconds
Spark Duration:	20 seconds
Inter-purge:	30 seconds
Soft Lockout / Reset:	30 minutes
Gas Valve Output:	2A maximum
Alarm Output:	2A maximum, dependent on optional alarm type
Operating Temperature:	-40°F to +185°F (-40°C to +85°C)
Environmental Protection:	Polyurethane encapsulated; 500 hour salt spray test to ASTM 117
Mating Connectors:	6 Pin: MOLEX 08-50-8063 or equivalent
Timing Specifications:	All timings are +/- 10%

NORMAL OPERATING SEQUENCE

Power up / Pre-purge

When powered up, the unit performs a series of diagnostic checks to determine if the system is in working order.

Trial for Ignition

After a 30 second pre-purge, the unit will power the valve solenoid and begin a 20 second trial for ignition. The spark will be enabled for the first 80% of the trial period and then suppressed for the last 20% of the trial period to allow the unit to sense weak flame signals.

Run

When a flame is sensed, the unit suppresses the spark and keeps the valve powered. Power is removed from the unit when the thermostat is satisfied.

ABNORMAL CONDITION OPERATING SEQUENCE

No Flame Established - *Soft Lockout Mode (30 minutes)*

If a flame is not established during the trial for ignition, the unit will perform an inter-purge and retrial for ignition. This protocol is followed for three (3) trials. If a flame is not established during the final ignition attempt, the unit will enter the soft lockout mode, which includes a reset delay before another normal trial for ignition series begins.

continued

Loss of Flame - Spark Restoration Retrial

If there is a loss of flame during the run mode, the unit will energize the spark within 0.8 seconds and perform a spark restoration trial for ignition. In this mode, the ignition means is restored without the gas valve being closed. If a flame is not established during the restoration trial, the unit will perform as in “*No Flame Established*” fault operation above.

Leaking Valve - Hard Lockout Mode

If a flame is present when the gas valve is not energized, the unit will enter the hard lockout mode.

Internal Fault - Hard Lockout Mode

If an internal fault is detected within the unit, the unit will enter the hard lockout mode.

System or External Fault - Hard Lockout Mode

If the unit detects a system fault or an external fault, the unit enters the hard lockout mode.

23. SPARK IGNITER SET UP

Use the following diagram to check the Igniter gap. If the gap is incorrect all adjustments should be made to the **GROUND PRONG/PIN ONLY!** **DO NOT BEND THE IGNITER PRONG!!!!**

USE THE BLACK BARS BELOW AS A GUIDE FOR ADJUSTMENT. USE THE BARS THAT COINCIDE WITH THE FORMAT & SIZE OF THIS PUBLICATION.

IF this manual is in
8.5" x 11" "booklet" format
(pages folded in half)
then use these bars →



OR

IF this manual is printed
8.5" x 11" "full page" format
use these bars →

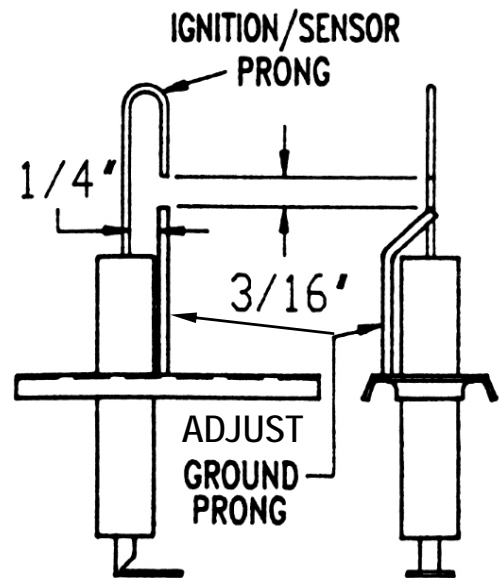
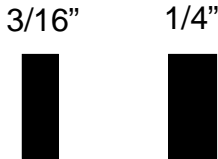

24. TROUBLESHOOTING GUIDE — HEATER OPERATION — FENWAL DSI



WARNING

Improper adjustment, alteration, service or maintenance can cause property damage, injury or death. This heater must be installed and serviced only by a trained gas service technician

SEQUENCE OF EVENTS (also see DSI Troubleshooting previous page)

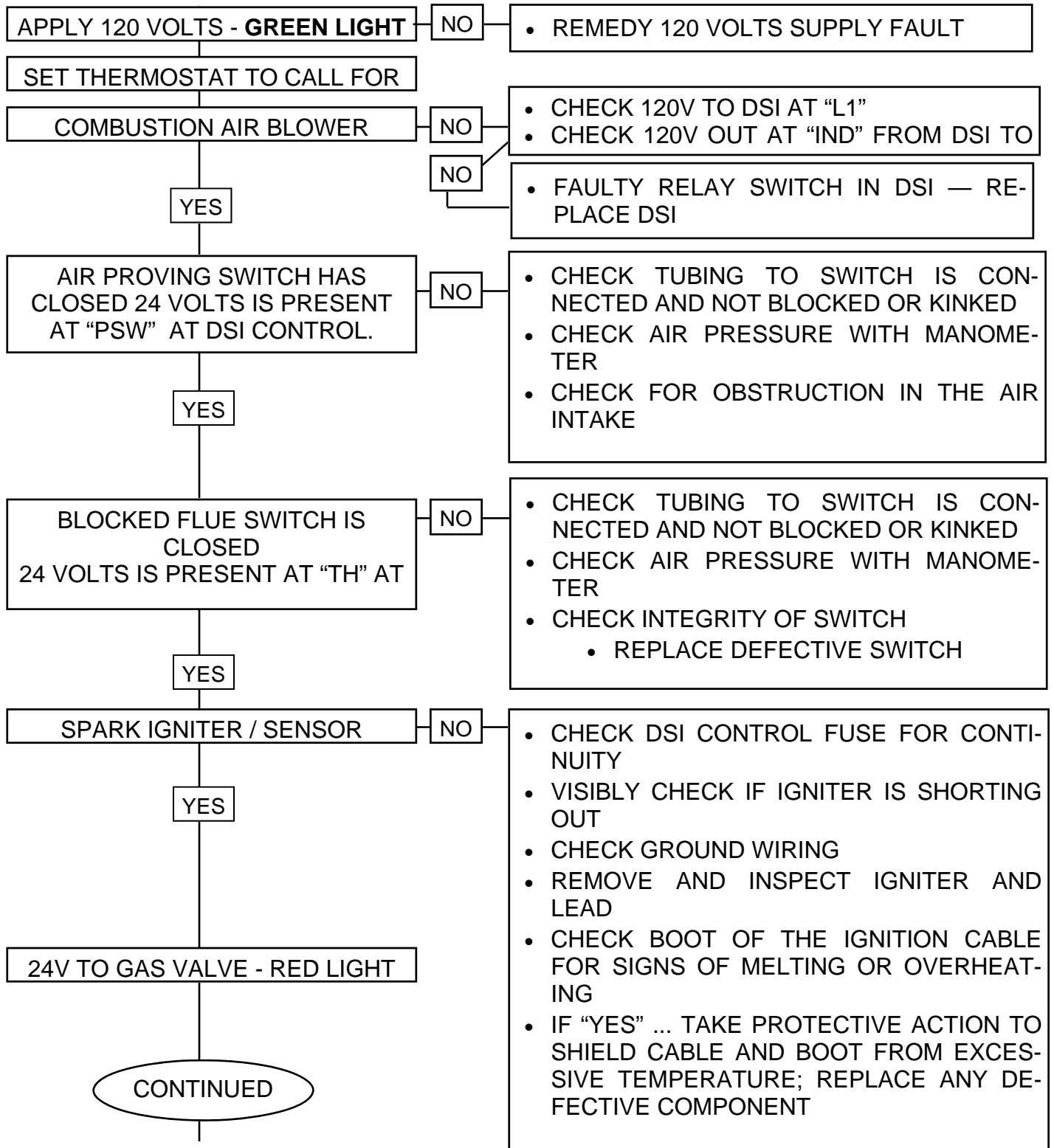

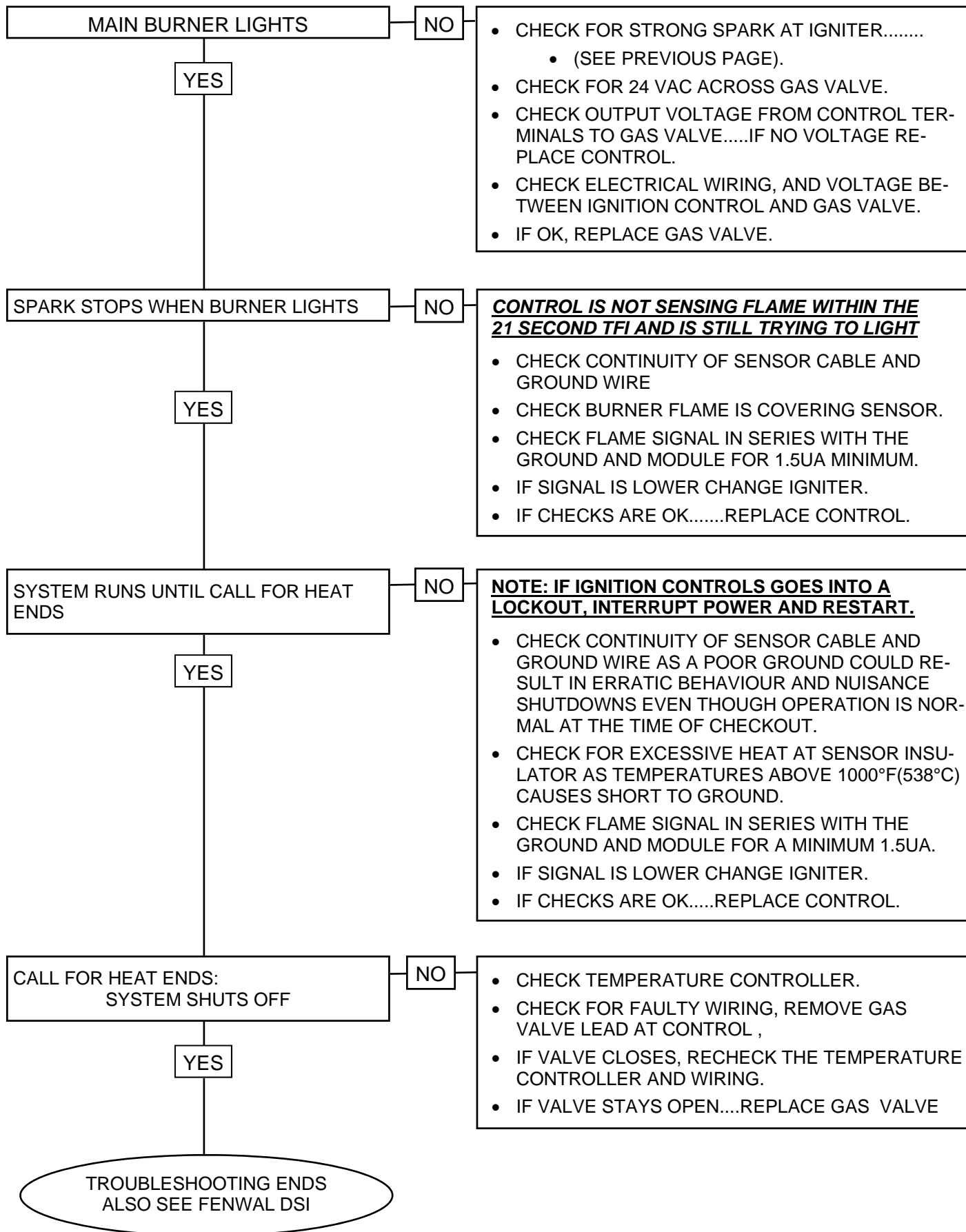

25. START-UP / COMMISSIONING SHEET



THIS EQUIPMENT HAS BEEN FACTORY FIRED AND TESTED PRIOR TO SHIPMENT. HOWEVER, THIS APPLIANCE IS NOT “PLUG & PLAY”. IT REQUIRES COMMISSIONING AND FIELD ADJUSTMENT / SPECIFICATIONS CONFIRMATION TO ENSURE SAFE AND EFFICIENT OPERATION.

**COMMISSIONING REPORT
AS PER I&O MANUAL AND LOCAL CODES**

CONTRACTOR NAME:DATE.....

ADDRESS:.....
.....

CITY:.....

PHONE:.....

CELL:

JOB SITE.....CITY.....

HEATER MODEL NUMBER:.....
Located on burner rating plate

HEATER SERIAL NUMBER:

TO ENSURE THAT SITE CONDITIONS ARE COMPATIBLE WITH THE HEATER’S PERFORMANCE AND TO ALLEVIATE NUISANCE CALL-BACKS, THE FOLLOWING START-UP NEEDS TO BE COMPLETED BY THE QUALIFIED GAS INSTALLER.

A TECHNICIAN CALLING FOR TECHNICAL SUPPORT MUST PROVIDE THE INFORMATION FROM THE COMPLETED COMMISSIONING REPORT ON THE NEXT PAGE

**FAX COMPLETED REPORT TO TECHNICAL SERVICES:
FAX 1-866-361-0523,
VOICE 1-877-446-3727**



START UP ‘SMOKE’

During start up, material coatings used in the production process of tubes and reflectors will “burn off” and create smoke during the first hour of operation. This is temporary and normal. Please ensure that there is sufficient ventilation to adequately clear the smoke from the space. Notify site and safety personnel to ensure that alarm systems are not unduly activated.

**QUALIFIED INSTALLER TO COMPLETE THIS
TUBE HEATER COMMISSIONING REPORT**

TYPE OF GAS: NG LP

DOES BUILDING HAVE A NEGATIVE CONDITION: YES NO

IF THIS IS A HIGH ALTITUDE AREA WHAT IS THE ALTITUDE ABOVE SEA LEVEL Ft

DOES APPLICATION REQUIRE FRESH AIR TO BURNER YES NO

IS HEATER EXPOSED TO CHEMICAL OR CORROSIVE ATMOSPHERE: YES NO

ARE ACTUAL MINIMUM CLEARANCES AS PER TABLE 3 YES NO

CAN HEATER BE AFFECTED BY OVERHEAD CRANES / VIBRATION YES NO

ARE GAS SUPPLY LINES ADEQUATELY SIZED FOR SYSTEM YES NO

GAS LINES AND BRANCHES HAVE BEEN PURGED OF AIR: YES NO

THIS HEATER FIRED WITHOUT ANY MALFUNCTION: YES NO

INLET GAS SUPPLY PRESSURE WITH HEATER OPERATING : WC"

GAS VALVE OUTLET (Manifold) PRESSURE WITH HEATER OPERATING: WC"

WHAT IS THE LINE VOLTAGE READING AT THE HEATER VOLTS

WHAT IS THE VOLTAGE READING AT THE IGNITION MODULE VOLTS

WHAT IS THE FLAME SIGNAL STRENGTH IN uA FROM SENSOR: uA (microamps)

IS HEATER CONTROLLED BY A THERMOSTAT YES NO

IS THE THERMOSTAT STRATEGICALY LOCATED YES NO

WHAT IS TOTAL LENGTH OF INSTALLED THERMOSTAT WIRE FEET

WHAT IS THE GAUGE OF THE THERMOSTAT WIRE GAUGE

WHAT IS THE HEATER TUBE LENGTH (10ft per Tube section) FEET

WHAT IS THE TOTAL LENGTH OF THE VENT (add 10ft for each bend) FEET

WHAT LENGTH IS COMBUSTION AIR INTAKE (add 10ft for each bend) FEET

IF REQUIRED....WHAT IS THE LENGTH OF THE TURBULATOR(S) FEET

IF INSTALLED....IS TURBULATOR AT FLUE END OF SYSTEM YES NO

"MAXIMUM STACKING HEIGHT" SIGN(S) - POSTED AT THERMOSTAT(S)

THIS HEATER MUST BE ELECTRICALLY GOUNDED

FAX COMPLETED REPORT TO TECHNICAL SERVICES: FAX 1-866-361-0523, VOICE 1-877-446-3727

26. DIMENSIONS AND WEIGHT

Assembled System:

- Weight: 86 pounds (39 kg)
- Dimensions: 119.5" L x 20" W x 12" H (3035 mm x 508 mm x 305 mm)

Burner:

- Weight: 26 pounds (11.8 kg)
- Dimensions: P40U: 16" L x 10.25" W x 10.75" H (406 mm x 260 mm x 273 mm)
P40U-P, -W: 20" L x 10.25" W x 10.25" H (406 mm x 260 mm x 260 mm)

Tube Reflector System:

- Weight: 70 pounds (27 kg)
- Dimensions: 103.5" L x 16.5" W x 7.5" H (2629 mm x 420 mm x 190 mm)

Turbulators (factory installed):

Burner side tube: 36" (914 mm)
Vent side tube: 90" (2286 mm)

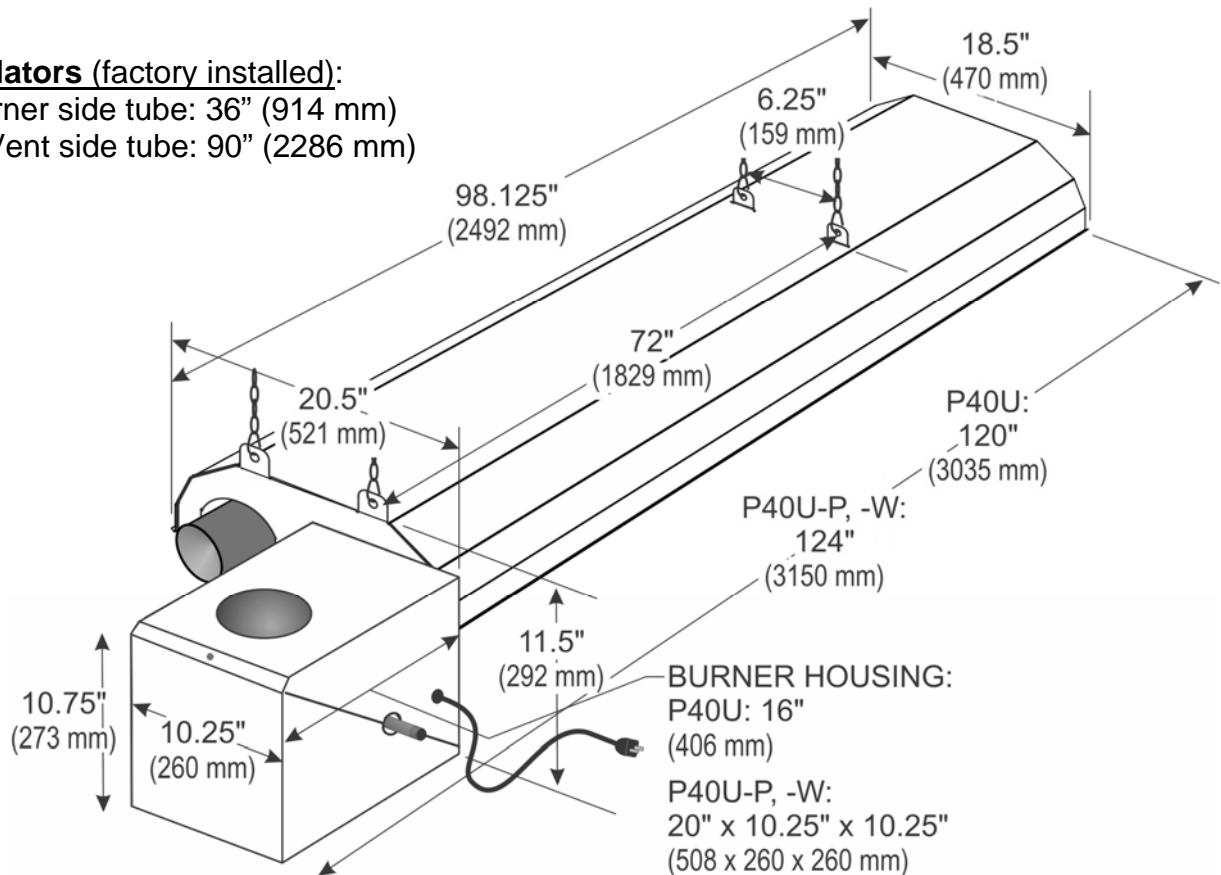

FLEXIBLE GAS CONNECTOR (Included in Burner Kit) - MUST INSTALL - see Section 13

USA - Stainless Steel Flexible Gas Connector

130,000 or less:
JL-0771-XX - 1/2"x24"

155,000 or more:
JL-0771-YY - 3/4"x36"

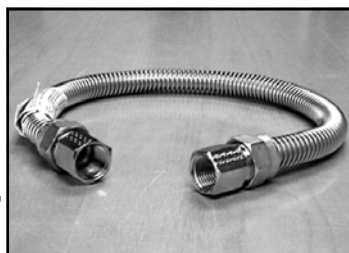

CANADA - Type 1 Hose Gas Connector

130,000 or less:
JL-0771-RC - 1/2"x36"

155,000 or more:
JL-0771-RB - 3/4"x36"



27. HIGH ALTITUDE INSTALLATION

When this appliance is installed above the altitude stipulated below, the input must be de-rated by 4% for each 1000 ft . **If your local utility supplies gas with a de-rated heat content, no orifice change is required in the heater** . Check with your local utility regarding de-rating.

USA: The factory installed orifice for this appliance is approved for altitudes zero to 2000 feet above sea level. Above 2000 feet, refer to table below.

Canada: The factory installed orifice for this appliance is approved for altitudes zero to 4500 feet above sea level. When installed above 4500 feet, refer to the table below

ORIFICE CHART - ALTITUDE CONVERSION

MODEL NO	FOR USE AT ALTITUDES ABOVE (FEET) Gas Orifice Drill Size / Part #							
	Supplied	USA Only			USA & CANADA*			
	0	2000	3000	4000	5000	6000	7000	8000
P40U / P40U-I NG	31 DMS JS-0731-DM	3 mm JS-0730-MM	32DMS JS-0732-DM	32DMS JS-0732-DM	33DMS JS-0733-DM	34DMS JS-0734-DM	7/64 JS-0731-IN	36DMS JS-0736-DM
P40U / P40U-I LPG*	49 DMS JS-0749-DM	50 DMS JS-0750-DM	50 DMS JS-0750-DM	50 DMS JS-0750-DM	51 DMS JS-0751-DM	51 DMS JS-0751-DM	51 DMS JS-0751-DM	52 DMS JS-0752-DM

* Field Conversion Kit required to convert between fuel gas types:

- Part number: JS-0555-XB P40U - Natural Gas to Propane Gas Conversion Kit
- Part number: JS-0555-XA P40U - Propane Gas to Natural Gas Conversion Kit

28. OPTIONAL ACCESSORIES

Flue Vent Terminal

4" wall horizontal
6" wall horizontal

JA-0528-XX
JA-0529-XX



Combustion Air Intake Terminal

4" Wall Intake Terminal (bird screened) JA-0532-VC

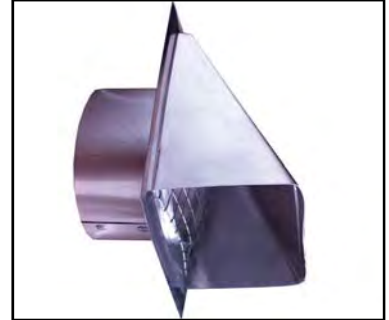

Torctite Coupler (c/w 2 bolts)

JA-0516-SW



Vent Tee 4" X 4" X 6"
(2 couplers optional)

JA- 0514-XX

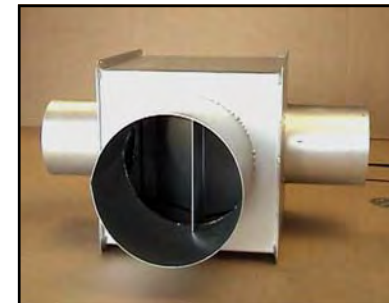

Clearance Sign - Metal 18" x 6"

JL-0798-CS

- Required in some jurisdictions:

- Vehicle service garages
- 3/4" high red lettering on white background



#2 Lion Chain (115 lb work load)
- 200 ft roll

JL-0800-XX

Safety Snap Hooks - 2" - pkg of 25
- pkg of 100



JL-0800-SH
JL-0800-SH-B



TruTemp Thermostat (24 Vac - 3-Wire)
True comfort control for radiant heating systems - senses and averages ambient and radiant temperatures.
Occupancy sensor with auto set-back of 9°F (5°C).
Do not use in wet or corrosive environments

JM-0150-XX



Low Voltage Digital Thermostat
(24 Volts - °F or °C selectable)
Not for use in corrosive or wet environments

JS-0569-WR



**For P40U-P, -W, -IP, -IW: Wet Environments
Moisture Proof Thermostat - NEMA 4X**
SPDT Line Voltage
40° - 110°F (5° - 40°C)
Both °F & °C Scales
Voltage: 24 - 277 Vac
Differential: 3°F
Stainless Steel Bulb
UL Listed

JS-0570-XX



Multiple Heaters per 24V Thermostat

Relay Switch: One required for each burner after the first burner in a zone (1st burner connects to 24V thermostat)

JS-0568 -CC

Refer to wiring diagram Page 26
(field installed at or in burner)



NOTE: FENWAL DSI has built in relay for blower operation

Line Voltage Thermostat:
Dual Scale: °F or °C

Use of line voltage thermostat disables post-purge feature of the ignition control.

JL-0772-XX

Not for use in corrosive or wet environments



JS-0502-UR-GK PROTECTIVE GUARD SCREEN OPTION – Zinc Plated; Two Piece Kit

– Recommended for heater mounted with less than 8 feet [2.4 m] between floor and bottom of heater or patio heating applications



Two sections make up the protective guard assembly that installs on the underside of the P40-U heater. Near the bottom edge at each side of the reflector are two sets of three holes. Each set of holes has one round hole at the center of the reflector, the other two holes are elongated and positioned between the center and the ends of the reflector. The pins that extend from each side of the two guard sections are inserted into these sets of holes.



Fig. 1



Fig. 2

Step 1: On ONE SIDE of the reflector, remove the bottom screws (Qty 3) that fasten the reflector to the end and center hanger brackets, Fig. 1. Retain screws for re-attachment of reflector .

Step 2: On the side of the reflector that remains securely fastened to the hangers, insert a pin located at the end of the Protective Guard into one of the 1/8" round holes located at the center of the reflector, Fig. 2



Fig. 3

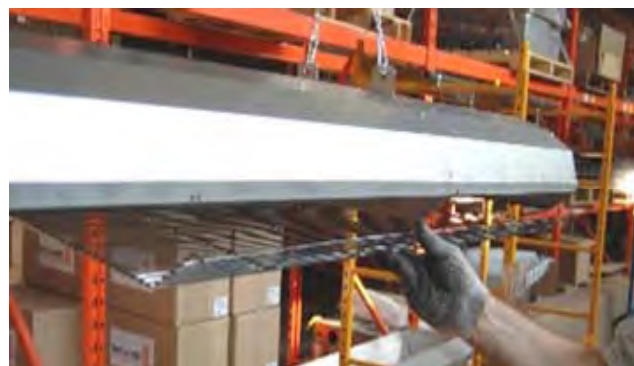

Fig. 4

STEP 3: Continue installing pins into the reflector until all three pins on one side of the heater are



Fig.5



Fig. 6

STEP 4: On the second side of the reflector, first Insert a guard pin into the center hole, Fig 5. Insert remaining guard pins in the reflector holes, Fig 6.

Step 5: Repeat the process with the second guard section.



Fig. 7

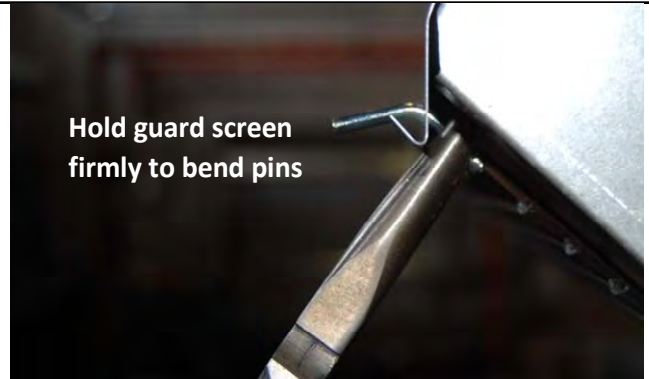

Hold guard screen firmly to bend pins

Fig. 8

Step 6: Re-install the screws at the bottom edge of the reflector into the three hangers, Fig. 7.



Fig. 9



Fig. 10 (Center)

Fig. 11 (End)

Notes:

- 1) To bend the pins, use needle nose pliers to hold the guard screen securely, Fig.8 and another set of pliers to bend the pin sideways, Fig.9.
- 2) DO NOT bend the pins downwards, it can damage the edge of the reflector.

STEP 7: To secure the guard in place bend the end pins of each guard section sideways and towards each other, Fig. 10 & 11. The center pin does not require bending.

29. REPLACEMENT PARTS LIST

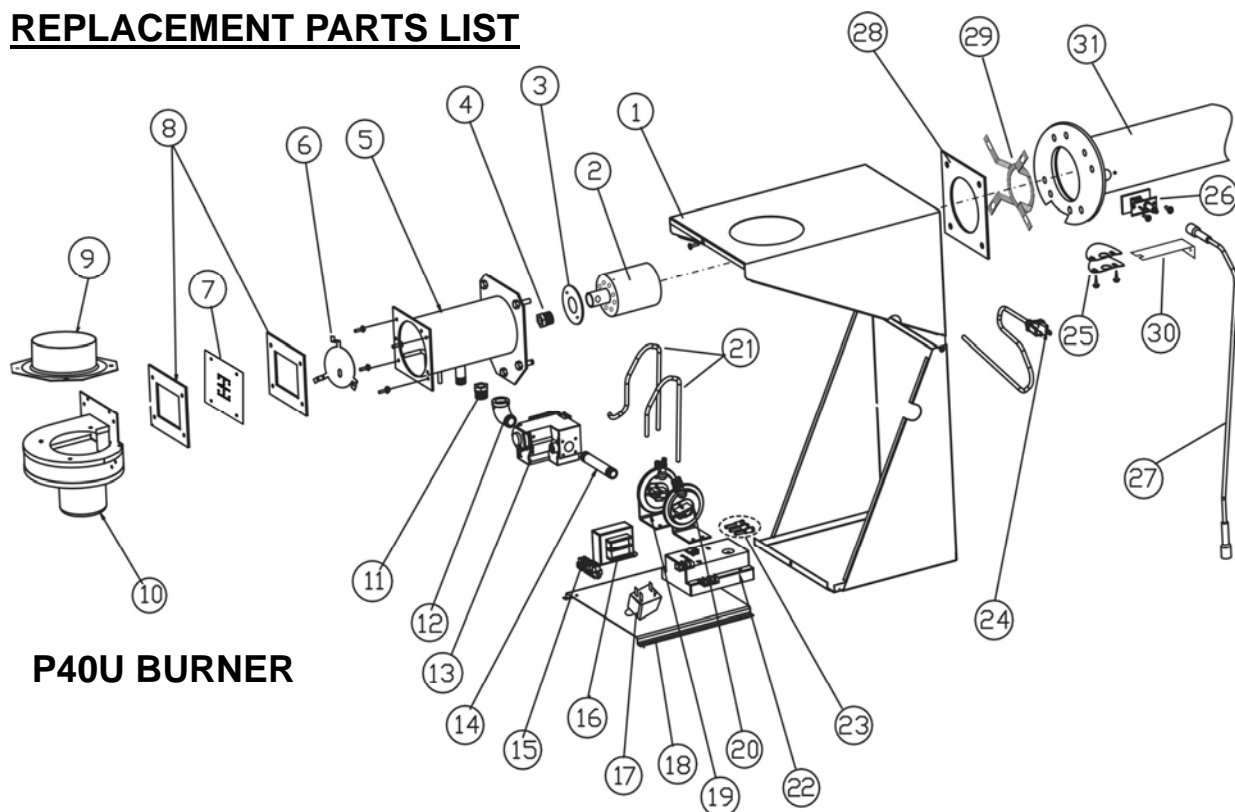

#	PART DESCRIPTION	PART #	PART DESCRIPTION PRIMARY	SUPPLEMENT
1	BURNER HOUSING: Schwank P40U	JS-0582-XX	Burner housing coated orange	P40U
	P40-R & InfraSave P40U-I	JJ-0582-XX	Burner housing coated grey	P40U-I; P40-R
2	BURNER CUP	JS-0512-UL	Burner Cup - Cast Aluminum	40 NG & LP
3	BURNER CUP AIR RESTRICTOR RING	JS-0596-RA-R	Burner Cup Air Restrictor Ring - 2 Holes	40 NG & LP
4	MAIN BURNER ORIFICE NG	JS-0731-DM	Gas orifice low intensity HR 31 DMS	40,000 NG
	LP	JS-0749-DM	Gas orifice low intensity HR 49 DMS	40,000 LP
5	BURNER CHAMBER	JS-0504-XX	Burner Chamber	All
6	BURNER AIR RESTRICTOR	JS-0592-RF	Burner air restrictor 40,000	40 NG & LP
7	EQUALIZER PLATE	JS-0593-EP-R	Outlet equalizer plate 40,000 - 13 Holes	40 NG & LP
8	BLOWER GASKET	JS-0578-XX	Blower gasket - Outlet	Each
9	AIR INTAKE ADAPTER / RESTRICTOR	JS-0595-UT	Air Intake Adapter/Restrictor - 1-1/4" Hole	P40U NG & LP
10	BLOWER	JS-0579-AA	Blower Assembly Tube Burner	
11	MANIFOLD BUSHING	JM-0589-XX	Manifold bushing	
12	90 DEGREE ELBOW FITTING 1/2"	JS-0588-XX	Street elbow fitting 90 deg	
13	GAS VALVE: Natural Gas	JL-0701-AA	Gas Valve comb 3.5" WC 24VAC VR8 NG	40,000 NG
	Propane	JL-0703-AA	Gas Valve comb 10" WC 24VAC VR8 LP	40,000 LP
14	4" NIPPLE	JS-0590-XX	Nipple 4"	
15	TERMINAL BLOCK	JM-0455-DD	Terminal block - Electrical Connections	
16	STEP DOWN TRANSFORMER	JA-0775-XX	Transformer 120/24V, 20VA AT120B1028	
17	24V/120V RELAY SWITCH	JS-0568-CC	24V/120V Relay Switch	
18	COMPONENT PLATE	JS-0581-SE	Component mounting plate SE	
19	COMBUSTION AIR PROVING SWITCH	JS-0576-UG	Air Proving Switch 1.00" WC	
20	BLOCKED FLUE PROVING SWITCH	JS-0577-RR	Blocked Flue Switch 0.46" WC	
21	PRESSURE SWITCH TUBING	JS-0572-SE	Tubing set 2 x 20" PVC SE	

Burners with FENWAL IGNITION CONTROL - Models: P40U-F; P40U-I-F

22	FENWAL DSI CONTROL	JA-0567-XX	3-Trial 24Vac with blower relay	"-F" Models
	REPLACEMENT KIT: FENWAL & S87J	JA-0568-KT	Fenwal Control + Wire Harness + Cable + Igniter: Replaces Fenwal & S87J	
27	IGNITION CABLE	JS-0518-SA	Hi voltage wire (24") STW - 2 x 1/4" Spades	

Burners with HONEYWELL S87-J IGNITION CONTROL - Models: P40U; P40U-I

22	HONEYWELL IGNITION CONTROL	JA-0568-XX	DISCONTINUED - NO LONGER AVAILABLE	
	REPLACEMENT KIT: FENWAL CONTROL	JA-0568-KT	Fenwal Control + Wire Harness + Cable + Igniter	
27	IGNITION CABLE HONEYWELL S87J	JS-0518-XX	Wire hi voltage (24") S87J Bullet Connection	

#	PART DESCRIPTION	PART #	PART DESCRIPTION PRIMARY	SUPPLEMENT
23	INDICATOR LAMPS	JW-0519-AM	Indicator light amber	
		JW-0519-GR	Indicator light green	
		JW-0519-RE	Indicator light red	
24	ELECTRICAL CORD	JB-0567-XX	Cord - electrical 6'	
25	SIGHT GLASS ASSEMBLY	JS-0536-XX	Sight glass assembly - tube heater	
26	IGNITER KIT	JA-0571-KT	Spark Igniter & Gasket Kit	
28	FLANGE GASKET	JS-0591-XX	Flange Adapter Gasket	
29	FLAME RECTIFIER	JS-0592-RR	Flame Rectifier	

PARTS UNIQUE TO:

- P40U-P
- P40U-W
- P40U-IP
- P40U-IW

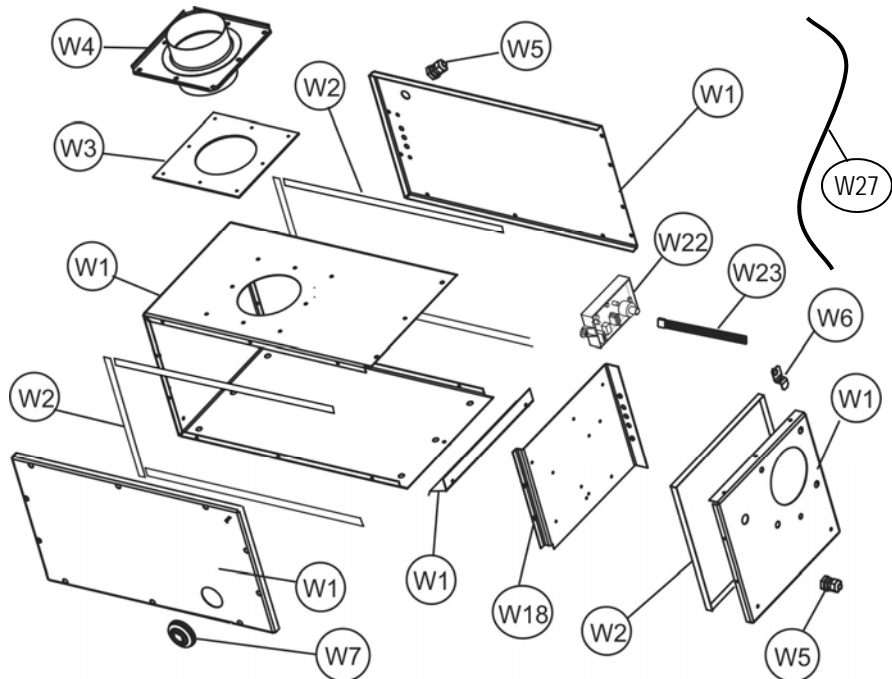

#	PART DESCRIPTION	PART #	PART DESCRIPTION PRIMARY	APPLICABLE
W1	BURNER HOUSING	JS-0582-WP-P	Powder Coated Burner Housing Wet Environment	Indoor/Outdoor
		JS-0582-WP	Stainless Steel Burner Housing Harsh Environment	Indoor/Outdoor
W2	BURNER HOUSING GASKET SET	JS-0591-WP	Housing gasket set	
W3	AIR INTAKE GASKET	JS-0601-WP	Air intake gasket	each
W4	COMBUSTION AIR INLET	JS-0583-WP	Powder Coated Combustion air inlet	
		JS-0583-15	Stainless Steel Combustion air inlet	
W5	SEALTIGHT CONNECTOR	JP-2036-XX	Connector liquid tight	
W6	BURNER STABILIZING BRACKET	JS-0583-05-P	Burner suspension bracket	
W7	WATERPROOF GROMMET	JP-2101-XX	Water proof butt connectors	
W18	COMPONENT PLATE	JS-0583-41	component mounting plate	
W22	IGNITION CONTROL	JB-0568-AA	Control - DSI 3 Try potted Gaslitter MICRO 50N	
W23	IGNITION CONTROL WIRING HARNESS	JB-0568-WH	3 Try potted spark DSI control wiring harness	
W27	IGNITION CABLE - MICRO 50N	JS-0518-SA	Hi voltage wire (24") STW - 2 x 1/4" Spades	

P40U TUBE / REFLECTOR SYSTEM - ALL MODELS

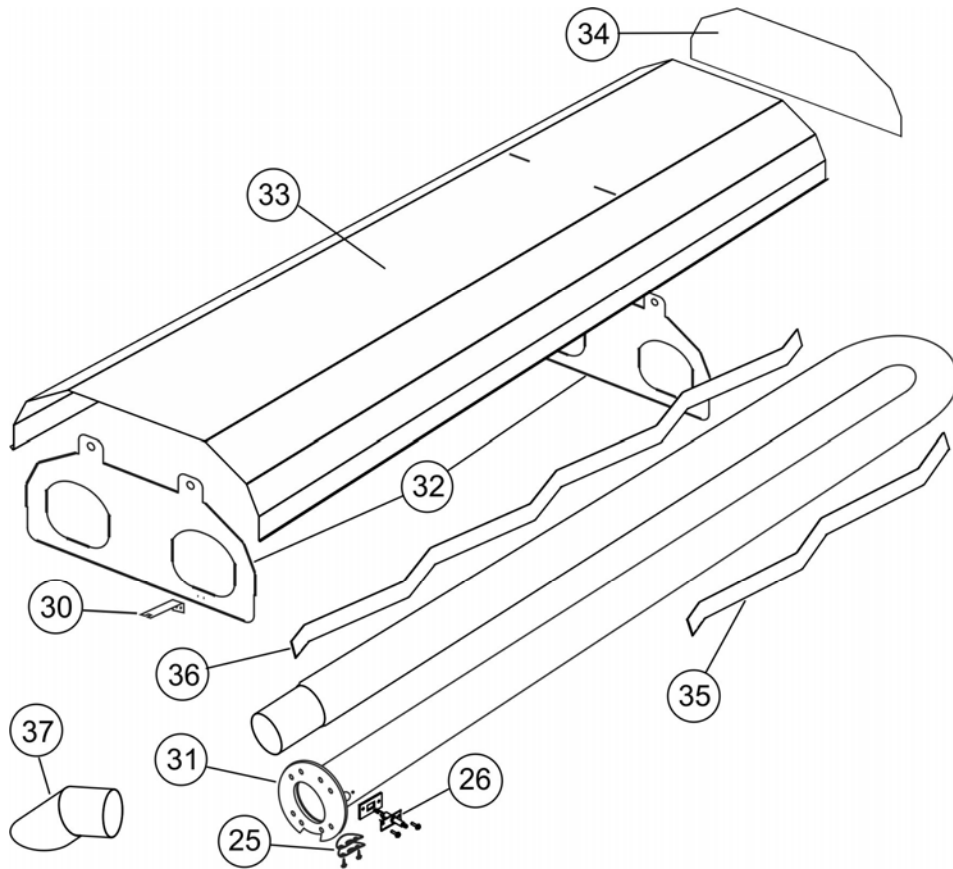



25	SIGHT GLASS ASSEMBLY	JS-0536-XX	Sight glass assembly - tube heater	
26	IGNITER KIT	JA-0571-KT	Spark Igniter & Gasket Kit	
30	TUBE FASTENING BRACKET	JS-0502-UV	Positions tube in hanger / reflector system	
31	PREFORMED U-TUBE	JA-0501-UT	Preformed U-Tube: 17 ft tube length	
32	P40U HANGER	JS-0506-UH	P40U System Hanger	
33	P40U REFLECTOR	JS-0502-UR	Reflector for P40U-xx	
34	REFLECTOR END PLATE	JS-0502-UT	Reflector End Plate	
35	P40U TURBULATOR 36"	JS-0533-US	36" Turbulator In Burner Side Tube	
36	P40U TURBULATOR 90"	JS-0533-UT	90" Turbulator In Vent Side Tube	
37	OPTIONAL VENT CAP	JA-0528-XX	Horizontal wall 4" vent terminal	Optional Item

HONEYWELL S87-J WIRING DIAGRAM P40U, P40U-I : 24V OR 120 VOLT THERMOSTAT

SINGLE HEATER PER THERMOSTAT

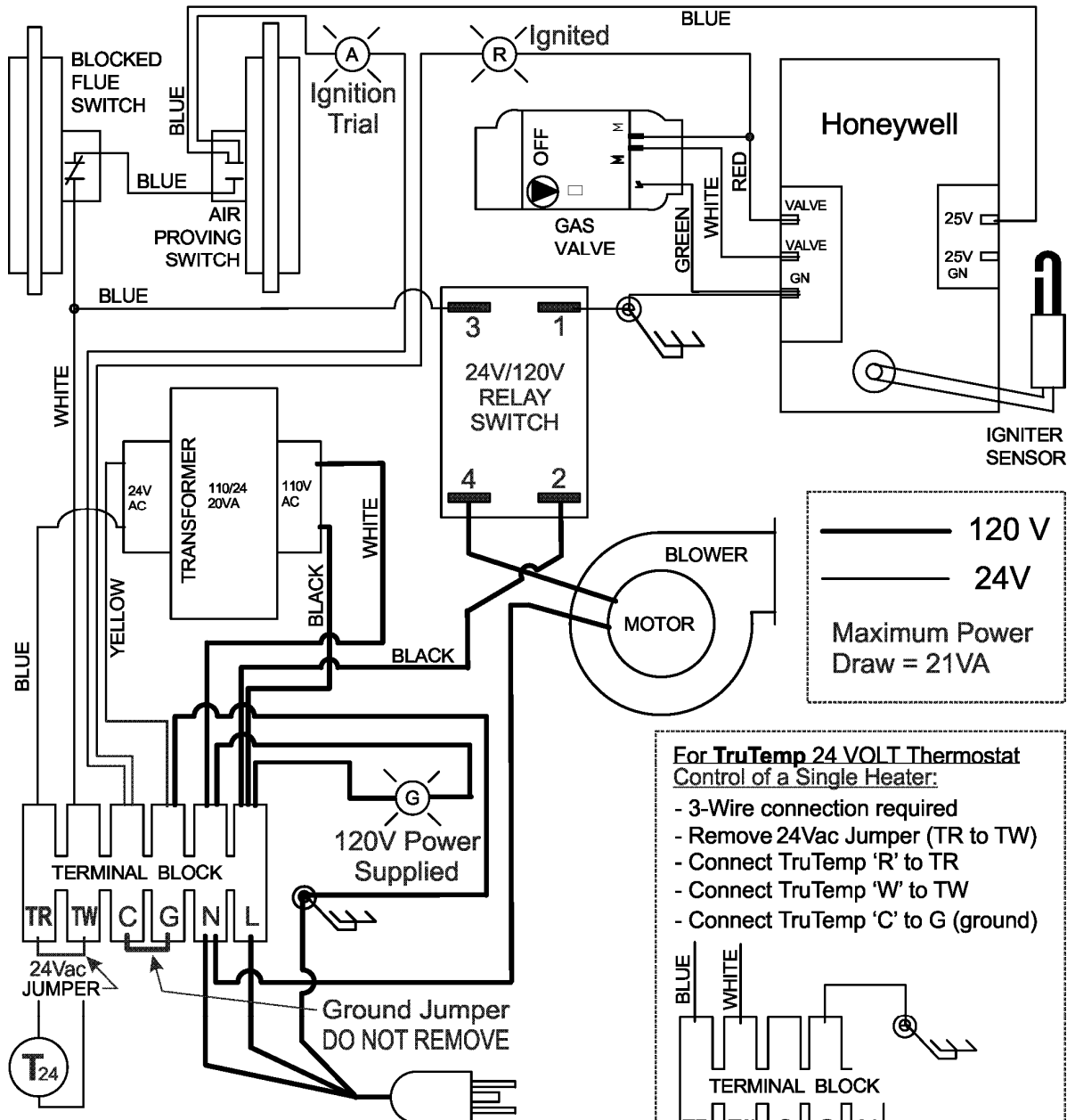
Models P40U-P, -W Next Page
Multiple Heaters/Thermostat ... Page 27



 120 V
 24V
 Maximum Power Draw = 21VA

For TruTemp 24 VOLT Thermostat Control of a Single Heater:

- 3-Wire connection required
- Remove 24Vac Jumper (TR to TW)
- Connect TruTemp 'R' to TR
- Connect TruTemp 'W' to TW
- Connect TruTemp 'C' to G (ground)

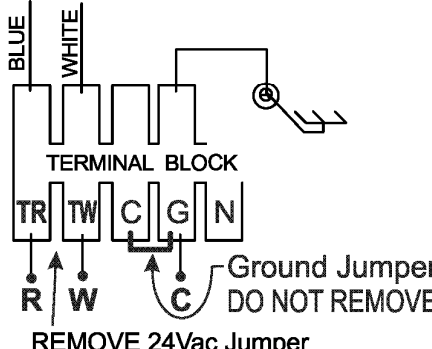

For 24 VOLT THERMOSTAT:

- REMOVE 24Vac Jumper
- Connect thermostat to TR & TW

LINE VOLTAGE THERMOSTAT

- Leave 24Vac Jumper in place.
- Install Line Voltage Thermostat in series with power supply.

Each tube heater requires 120V, 60 HZ electrical power sized for 145VA. The heater includes a 24V/120V relay switch . Maximum power draw for internal 24V burner components is 21VA.

The heater must be electrically grounded in accordance with the National Electrical Code. ANSI / NFPA 70 or current Canadian Electrical code CSA C22.1.

A maximum night set-back of 9°F (5°C) is recommended for optimum economy and comfort. To maintain satisfactory comfort levels do not turn off the heating system over night/weekends.

HONEYWELL S87J: MODELS P40U, P40U-I SEQUENCE OF OPERATION

The S87 ignition control module is powered by a 24v transformer and activated when the thermostat calls for heat. On every call for heat the S87J will delay start-up to provide a 30 second system pre-purge. When the S87 is activated by a thermostat or call for heat an internal transformer provides power to the electronic generator circuit for Spark Ignition and the safety lock-out timing begins. At the same time, the S87 opens the gas controls main valve allowing gas to flow to the main Burner.

The S87 Control Module performs the following basic functions:

- Provides a 30 second system pre-purge
- Supplies power to the electronic pulse-generator circuit for the Spark Igniter (30,000 volts open circuit).
- Allows 21 seconds for Ignition trial (TFI) before system safety lockout occurs.
- Senses the Burner flame for safe lighting
- Shuts off the spark after the Burner is lit.

Burner with direct spark ignition, sequence is as follows :

- 1a. **Line Voltage Thermostat:** Upon a call for heat by the line voltage Thermostat or “ON/OFF” switch, the Blower and the 120/24 volt Transformer are powered simultaneously with 115 volts.
- 1b. **24 Volt Thermostat:** The 120 volt supply to heater will power the 120v/24v Transformer and the 120V side of the Blower switching relay simultaneously. A call for heat by the 24 volt Thermostat energizes the 24 volt control circuit and the 24v/120 volt relay powering the Blower.
2. The 24 volt control circuit powers the DSI control in series through the normally open Air Pressure Switch (APS) and the normally closed Blocked Flue Switch (BFS).
3. The Blower creates a positive pressure and closes a normally open contact inside the Air Proving Switch (APS).
4. 24 volts supplied to the DSI control initiates the 30 second pre-purge cycle.
5. After completing the 30 second pre-purge cycle the DSI control generates high voltage to the Spark Igniter, and 24 volts to energize the Gas Valve.
6. The Burner will light and establish a steady flame.
7. Once the flame sensor determines there is a steady flame established, with a minimum flame signal of 1.5 μ A the spark igniter is then de-energized.
8. In the event ignition does not occur, the safety circuit will function to interrupt gas flow after approximately 21 seconds and lock the system out. No further gas will flow until the power has been manually interrupted for a period of 30 seconds. This will reset the ignition module and the operating sequence will restart at step #1
9. If the blower does not run, the blower air pressure switch (normally open contact) does not close and power is not supplied to the ignition control.

HONEYWELL S87 DSI: MODELS P40U (-I) - FLAME SENSING CIRCUIT

The output of the flame sensing circuit cannot be checked directly on the S87 body. Check the flame sensing circuit directly by checking the flame sensing current from the sensor to the S87 as follows.

1. Connect a meter (dc microammeter scale) in series with the flame signal ground wire as shown below. Using the Honeywell W136A Test Meter or equivalent. Disconnect the ground wire from the S87. Connect the red (positive) meter lead to the free end of the ground wire. Connect the black (negative) meter lead to the quick-connect ground terminal on the S87.
2. Restart the system and read the meter. The flame sensor current must be at least 1.5 uA and steady. If the reading is less than 1.5µA or unsteady, see LOW OR UNSTEADY FLAME CURRENT section, below.

If a flame is present at sensor and a reading of zero uA is obtained, check for a secondary ground connection to the 24V (GND) terminal. If secondary connection exists, temporarily remove connection and measure flame current.

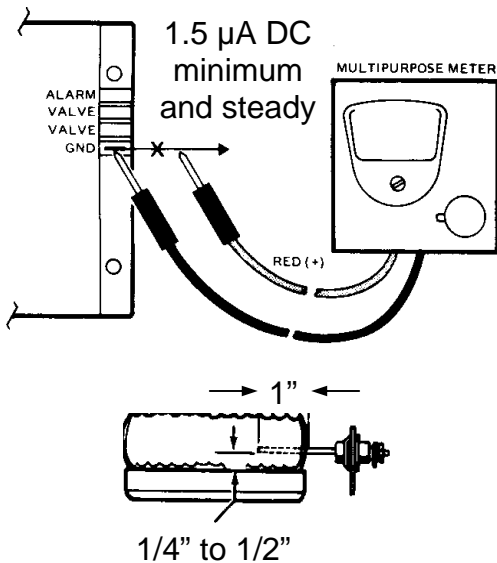

A good rectifying flame is achieved with approx 1" of sensor in a strong blue flame, positioned 1/4" to 1/2" away from flame source surface.



A lazy or weak flame is not a good rectifying flame. Check gas pressure and gas orifice for insects, and spider webs.

LOW/ UNSTEADY FLAME CURRENT

If the current to the S87 flame circuit is less than 1.5 µA or is unsteady, check the burner flame, flame sensor location and electrical connections as follows.

Electrical Connections and Shorts

Connections at the flame sensor must be clean and secure. If wiring needs replacement, use moisture resistant #18 wire rated for continuous duty up to 221⁰ F [105⁰ C].

Flame Sensor

The flame signal is best when about 1 in. [25 mm] of flame rod is immersed in the burner flame. A bent flame rod, bent mounting bracket or cracked ceramic insulator will affect flame signal.

Replace flame sensor if necessary.

Burner Flame

The flame sensor must be constantly immersed in flame. Check burner flame condition as shown opposite. Observe burner rating plate for the correct gas pressure, and check with a manometer. If gas pressure is correct check line and orifice for obstructions.

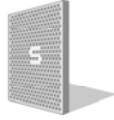

FOR GAS-FIRED INFRA-RED LOW INTENSITY TUBE HEATERS: P40U (-P, -W) & P40U-I (-IP, -IW) SERIES

The Manufacturer warrants that this product is free from defects in material or workmanship under normal use and service subject to the terms of this document.

THREE YEAR WARRANTY

Subject to the conditions and limitations stated herein, during the term of this limited warranty, we will supply any component part (at our option a new or repaired component part) of the heater as defined below, excluding any labor, which the Manufacturer's examination determines to be defective in workmanship or material for a period of three years (3 years) from the date of installation, unless otherwise specified below. This warranty applies to the heater's original owner, and subsequent transferees and only if the unit is installed and operated in accordance with the printed instructions accompanying the unit and in compliance with all applicable installation codes and good trade practices. Warranty is only applicable to Schwank components, other parts are limited to their own Manufacturers warranty period of one year (1 year).

TEN YEAR WARRANTY

The Manufacturer warrants the burner sub-assembly comprising of ceramic and immediate metal tubing, and the radiating tubes (excluding couplings) for a period of ten years (10 years).

WHAT IS NOT COVERED

The Manufacturer shall not be responsible for any expenses, including service, labor, diagnosis, analysis, material or transportation charges incurred during removal or reinstallation of this product, or any of its components or parts. All labor or service charges shall be paid by the owner. This warranty does not cover heating products improperly installed, misused, exposed to or damaged by negligence, accident, corrosive or contaminating atmosphere, water, excessive thermal shock, impact, abrasion, normal wear due to use, alteration or operation contrary to the owner's manual or if the serial number has been altered, defaced or removed. This warranty shall not apply if the input to the heating product exceeds by more than 2% of the rated input on the rating plate. The Manufacturer shall not be liable for any default or delay in performance by its warranty caused by any contingency beyond its control, including war, government restrictions, or restraints, strikes, fire, flood, acts of God, or short or reduced supply of raw materials or products.

WARRANTY PROCEDURE

To establish the installation date for any purpose under this Limited Warranty, you must retain the original records that can establish the installation date of your unit. If you do not provide such documents, the start date of the term of this Limited Warranty will be based upon the date of unit manufacture, plus thirty (30) days. Failure to maintain the equipment through regular annual service maintenance by a qualified service technician shall void the warranty.

LIMITATIONS AND EXCLUSIONS

This document contains all warranties made by the Manufacturer and may not be varied, altered or extended by any person. There are no promises, or agreements extending from the Manufacture other than the statements contained herein. THIS WARRANTY IS IN LIEU OF ALL WARRANTIES EXPRESSED OR IMPLIED, TO THE EXTENT AUTHORIZED BY THE LAWS OF THE JURISDICTION, INCLUDING SPECIFICALLY THE WARRANTIES OR MERCHANTABILITY OF FITNESS FOR A PARTICULAR PURPOSE.

It is understood and agreed that the Manufacturer's obligation hereunder is limited to repairing or replacing parts determined to be defective as stated above. In no event shall the Manufacturer be responsible for any alleged personal injuries or other special, incidental or consequential damages. As to property damages, contract, tort or other claim the Manufacturer's responsibility shall not exceed the purchase price paid for the product.

All replacement parts will be warranted for the unused portion of the warranty coverage period remaining on the applicable unit.

Some Authorities do not allow certain warranty exclusions or limitations on duration of warranty or the exclusions or limitations of incidental or consequential damages. In such cases, the above limitations or exclusions may not apply to you and are not intended to do so where prohibited by law. This warranty gives you specific legal rights. You may also have other rights which vary by jurisdiction.

SCHWANK GROUP
2 SCHWANK WAY, WAYNESBORO, GEORGIA. 30830
5285 BRADCO BLVD. MISSISSAUGA, ON, L4W 2A6

Ph: 1-877-446-3727
www.SchwankGroup.com

Fax: 1-866-361-0523
www.InfraSave.com